

CoreSync Emergency Lighting Bypass

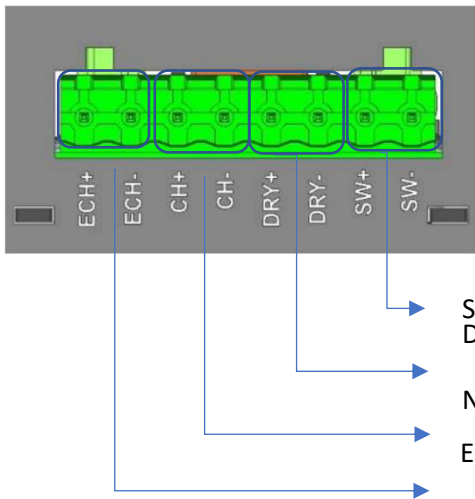

INSTALLATION INSTRUCTIONS

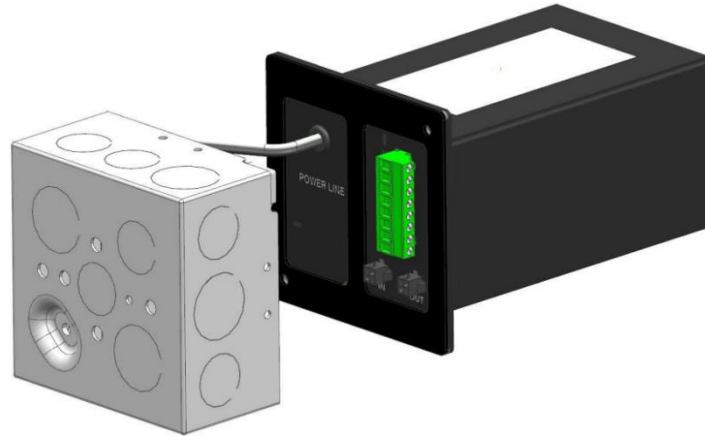

Switch
Dry Contact

Non-Emergency Channel

Emergency Channel

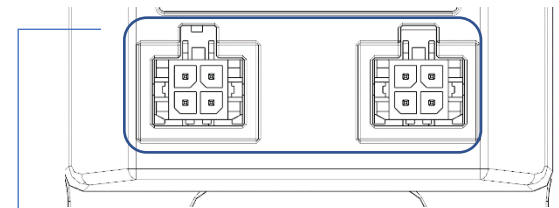

4-pin Micro Fit 3.0 Connector
for CoreSync Bus IO
42-57 VDC + RS485 Data Line

Order No. Single	Order No. Dual	Description
182135-1207	182135-1217	CoreSync Emergency Lighting Bypass 300mA
182135-1201	182135-1211	CoreSync Emergency Lighting Bypass 350mA
182135-1202	182135-1212	CoreSync Emergency Lighting Bypass 500mA
182135-1203	182135-1213	CoreSync Emergency Lighting Bypass 700mA
182135-1206	182135-1216	CoreSync Emergency Lighting Bypass 880mA
182135-1204	182135-1214	CoreSync Emergency Lighting Bypass 1050mA

Molex is a registered trademark of Molex, LLC in the United States of America and may be registered in other countries; all other trademarks listed herein belong to their respective owners

INSTALLATION INSTRUCTIONS

1. CAUTION AND WARNING

- **CAUTION** – Observe precautions for handling electrostatic sensitive devices.
- **WARRANTY** – Voided if device has been modified from its original configuration or in the event of hot plug/hot swap.
- **WARNING** – Risk of Electric Shock. Do not handle energized module with wet hands or when standing on wet or damp surfaces.
- **DO NOT** DISASSEMBLE EMERGENCY LIGHTING BYPASS.
- **DO NOT** connect the CoreSync Harness when Gateway is energized
- **DO NOT** handle energized unit with wet hands or when standing on wet or damp surfaces.
- Risk of electric shock.
- **DO NOT** use in elevated temperature environment – more than 55°C
- **DO NOT** use Outdoors
- Only to be used with CoreSync System
- Use appropriate Junction Box depending on the installation space (Plenum / Non-plenum)

EMERGENCY LIGHTING BYPASS MUST BE INSTALLED BY A CORESYNC CERTIFIED TECHNICIAN AND QUALIFIED ELECTRICIAN (CHECK WITH LOCAL AND NATIONAL CODES FOR PROPER INSTALLATION)

2. Required Hardware

The following outlet and junction boxes should be used with Emergency Lighting Bypass:

1) OUTLET BOXES

A. Sheet Metal Outlet Boxes: NEMA OS 1, UL 514A; galvanized steel with stamped knockouts:

1. Luminaire and Equipment Supporting Boxes: Rated for weight of equipment supported 1/2" male fixture studs, where required
2. Concrete Ceiling Boxes: Concrete type

B. Cast-Metal Outlet Boxes: NEMA FB 1, cast aluminum or cast iron (galvanized), Type FD, with gasketed cover and threaded hubs Gang-able type boxes are not allowed

Following box manufacturers are recommended:

- a) Raco 233 box with partition #707RAC
- b) Crouse-Hinds TP436 box with partition
- c) OZ-Gedney-Appleton 4SD-1 box with partition
- d) Thomas & Betts 52171-1 box with partition
- e) Garvin Industries 52171-1-VT box with partition #707RAC for planum rated environment

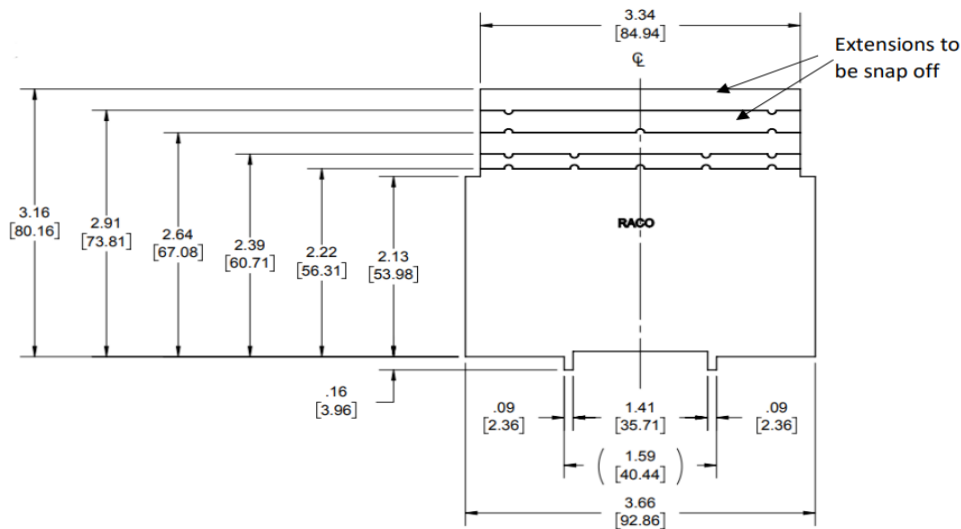

Molex is a registered trademark of Molex, LLC in the United States of America and may be registered in other countries; all other trademarks listed herein belong to their respective owners

INSTALLATION INSTRUCTIONS

Partition, part number 707RA

Two partition extensions should be snapped off, formed and insert the way as shown below, to support the partition.

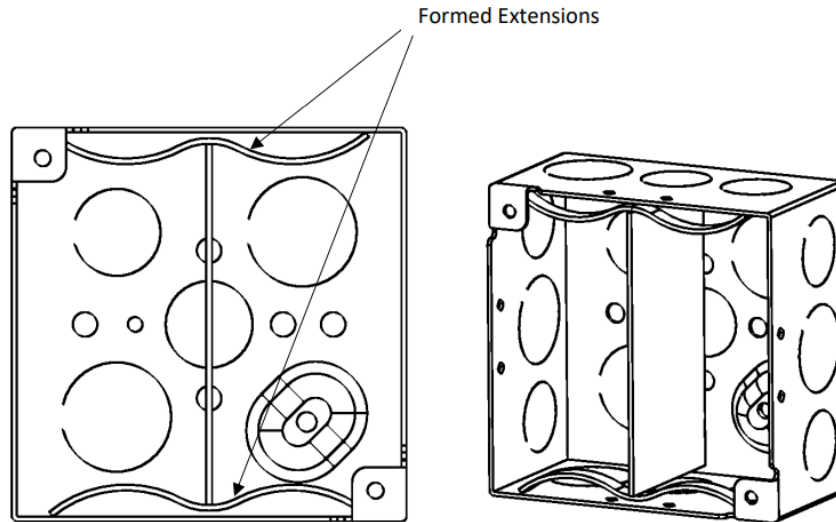

2) PULL AND JUNCTION BOXES

- A. Small Sheet Metal Pull and Junction Boxes: NEMA OS 1; galvanized steel
- B. Metal, Pull, and Junction Boxes: NEMA FB 1; cast aluminum or galvanized, cast iron with ground
- C. Flanged boxes not allowed without prior approval of local authority having jurisdiction

INSTALLATION INSTRUCTIONS

3. Procedures

Step 1. Confirm if Plenum rated junction boxes are required with airtight knockouts, and gasketed covers prior to install

Step 2. Refer to emergency Lighting Device Installation Instruction and required pinouts prior to junction box and raceway installation

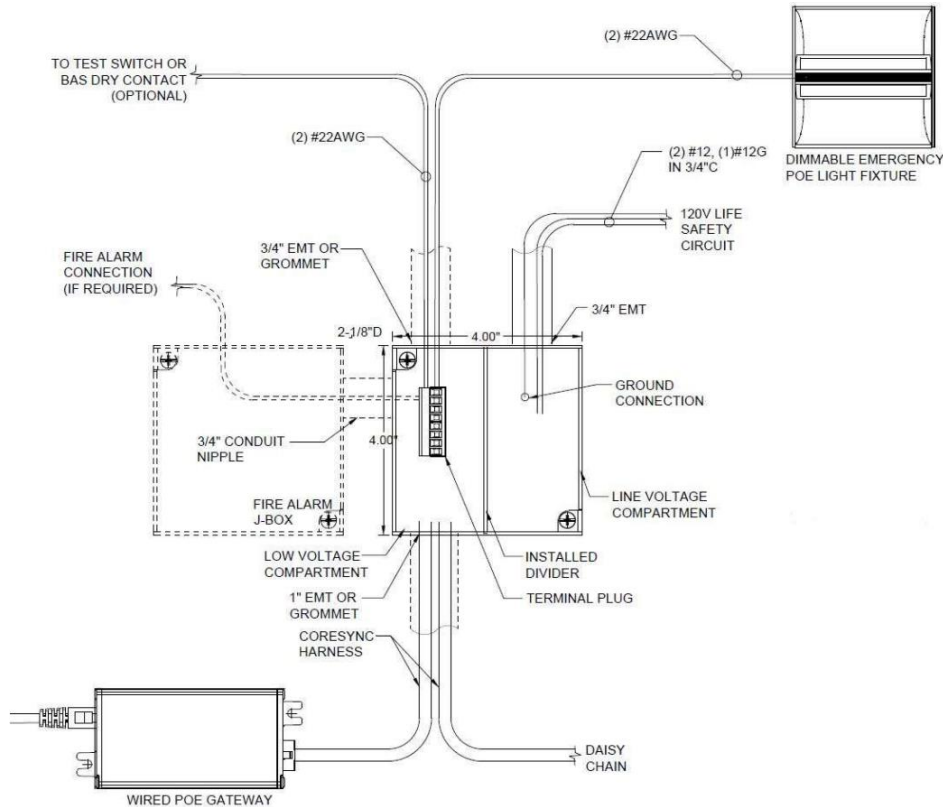

Diagrams to complete the wiring installation

Step 3. A barrier between the line voltage and low voltage compartments to be installed by EC

Step 4. EC to provide and install standard 4x4 junction box and terminate conduit as required

Step 5. EC to provide grommets where required

Step 6. EC shall terminate line voltage wiring to Emergency Lighting Bypass Device as required per NEC

Step 7. Terminate low voltage wires to the terminal plug as required , and plug in CoreSync harness

Step 8. Secure terminal plug onto device terminal block

Step 9. Mount Device onto the junction box via two screws supplied with the junction box

Step 10. Please refer to the wiring and connection diagrams as shown in pg.3 and pg.4

Molex is a registered trademark of Molex, LLC in the United States of America and may be registered in other countries; all other trademarks listed herein belong to their respective owners

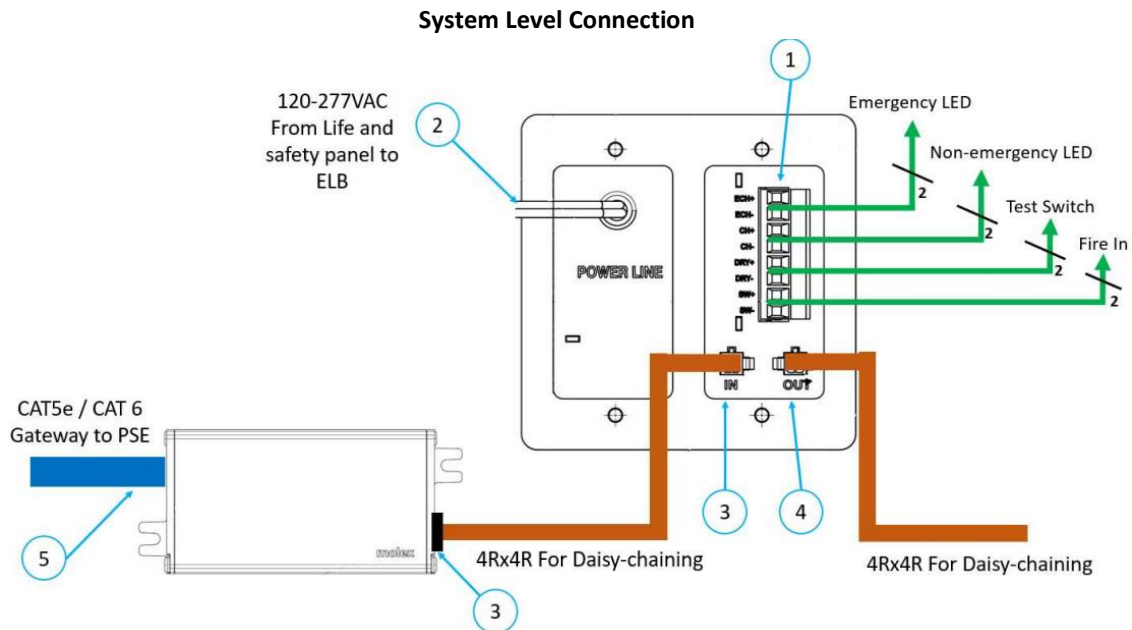

1. Connection to LED load, fire alarm and test switches
2. 120-277V AC power from life and safety panel to ELB
3. Molex harness from the PoE gateway to the panel mount micro-fit input on the ELB
4. Molex harness from the panel mount micro-fit output connector on ELB to the next CoreSync device in the daisy chaining
5. Molex harness CAT5e /CAT 6 PoE input from the PoE switch (PSE) to the CoreSync PoE gateway

INSTALLATION INSTRUCTIONS

4. Terminal Block Connection

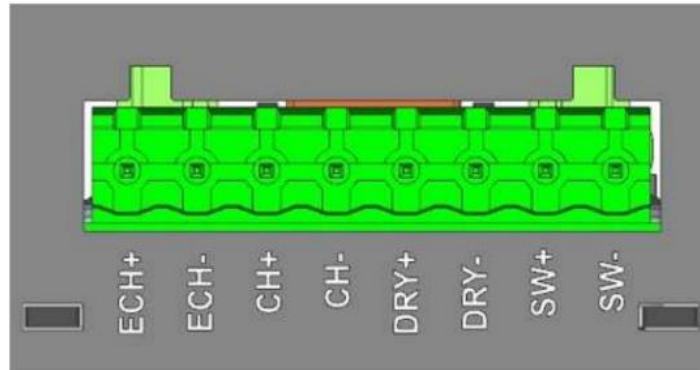

- 1) ECH - Constant Current LED Out to drive the emergency channel (Fixture)
- 2) CH - Constant current LED Out to drive non-emergency channel (Only when used with a tunable driver)
- 3) DRY - Normally-open dry-contact input connects to the fire alarm system. On activation, the ELB changes to emergency mode, turning on the luminaire to maximum brightness.
- 4) SW - This is a illuminated round shaped pushbutton used to simulate emergency operation. The LED stays on as long as PoE is present and goes off in cases of emergency.

5. CALCULATING MAX CONNECTED DEVICES:

The IEEE 802.3bt standard guarantees at least 71.3W at the input of the Gateway. Using this number and the max power consumption of 3.2W for this gateway, provides 68.1W of connected devices. Please use individual data sheets of the connected devices in tandem with the CoreSync Harness Length Calculator to determine the maximum power consumption. For further details please refer to the CoreSync Academy Module “Device Layout & Design Overview”.

- LEGAL DISCLAIMER -

The author has made every attempt to ensure the accuracy and reliability of the information provided in this document. However, the information is provided "as is" without warranty of any kind. Molex does not accept any responsibility or liability for the accuracy, content, completeness, legality, or reliability of the information contained in this document.

This document is provided to you solely for your own personal use and may not be used for resale, distribution, public display or performance or other similar uses by you. The materials in this document as well as its photographs, images, layout, organization and design are copyrighted and are protected by worldwide copyright laws and treaty provisions. Trademarks, logos and service marks displayed on this site are registered and unregistered trademarks of Molex, its licensors or content providers, or other third parties. All of these materials, trademarks, logos and service marks are the property of their respective owners.

Molex Connected Enterprise Solutions 



Molex is a registered trademark of Molex, LLC in the United States of America and may be registered in other countries; all other trademarks listed herein belong to their respective owners