

INSTALLATION INSTRUCTIONS: PID-00231 PANEL

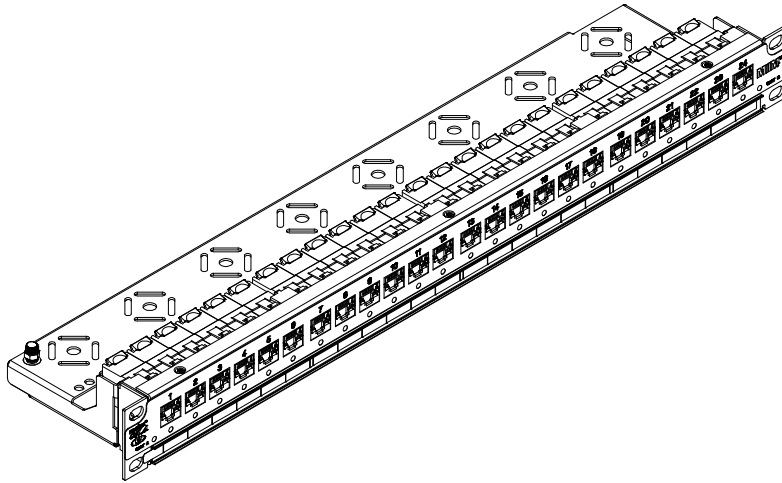

PARTS LIST

Panel with Integrated Cable Manager
 Hardware Kit
 Rear Housing Assembly
 Stuffer Caps
 Labels
 Instruction Sheet

GENERAL REQUIREMENTS

The following tools are required for installation of the panel:

110 termination tool set on low impact
 Flush cut pliers
 Cable stripping tool
 Phillips screwdriver

ASSEMBLY INSTRUCTIONS

1. Panel Preparation

- 1a. Remove cable management tray from panel.
- 1b. For each cable, slide rear housing on cable in the proper direction.

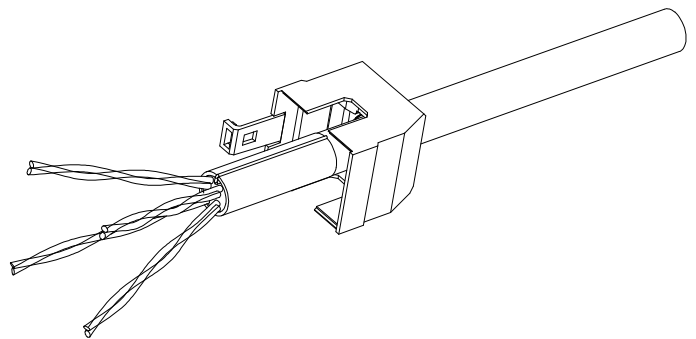

Fig.1b

MPN NO.	SAP NO.
215-390	187000372

REVISION: A	ECR/ECN INFORMATION: EC No: MTS2012-0032 DATE: 2013 / 01 / 21	TITLE: Installation Instructions PID-00231 MIIM Category 6A Patch Panel	SHEET No. 1 of 4
DOCUMENT NUMBER: AS-18700-059	CREATED / REVISED BY: BJ Mahendra	CHECKED BY: CG Raghavan	APPROVED BY: Samuel Huber

2. Cable Preparation

2a. U/FTP

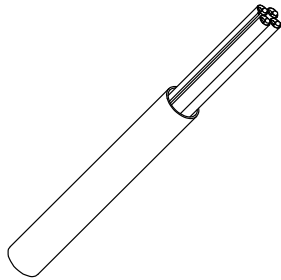

Fig.1

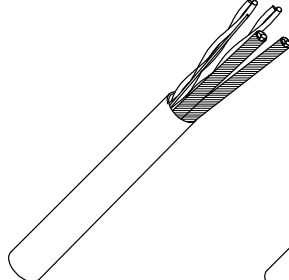

Fig.2

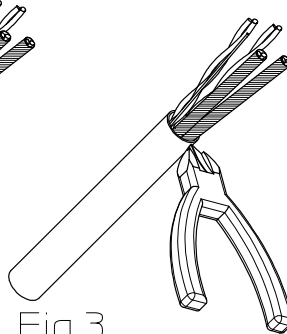

Fig.3

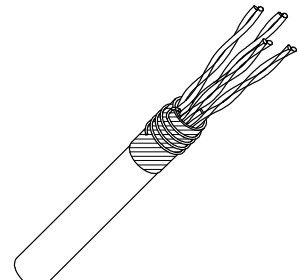

Fig.4

- 1) Strip the cable a minimum of 40mm.(Fig. 1)
- 2) Remove foil from three pairs and untwist pairs. (Fig. 2)
- 3)Use clippers to cut-off foil. (Fig. 3)
- 4) Pull the foil shield back from the forth pair over the jacket. Ensure the cable foil's conductive surface is facing out. Wrap the drain wire around the foil shield. (Fig. 4)

2b. F/UTP

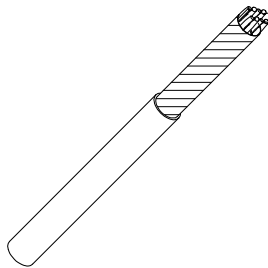

Fig.1

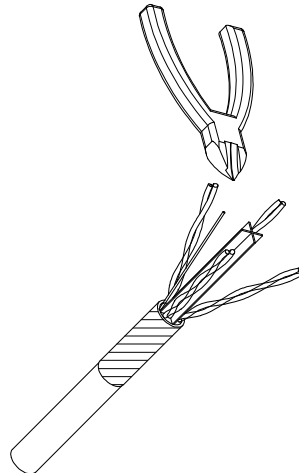

Fig.2

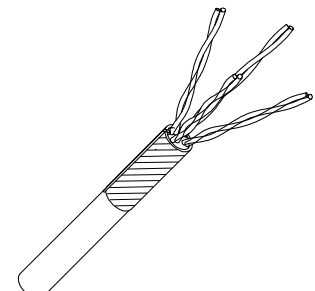

Fig.3

- 1) Strip the cable a minimum of 40mm. (Fig. 1)
- 2) Untwist pairs and remove cable separator with wire clippers. (Fig. 2)
- 3) Pull the foil shield back over the jacket. Ensure the cable foil's conductive surface is facing out.Wrap the drain wire around the foil shield. (Fig. 3)

MPN NO.	SAP NO.
215-390	187000372

REVISION: A	ECR/ECN INFORMATION: EC No: MTS2012-0032 DATE: 2013 / 01 / 21	TITLE: Installation Instructions PID-00231 MIIM Category 6A Patch Panel	SHEET No. 2 of 4
DOCUMENT NUMBER: AS-18700-059	CREATED / REVISED BY: BJ Mahendra	CHECKED BY: CG Raghavan	APPROVED BY: Samuel Huber

3. Cable Termination

3a. Untwist wires and position for terminating.

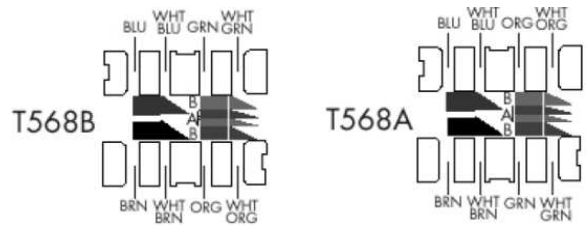

Fig. 3a.

3b. Position cable to align each pair with corresponding color code. Ensure cable sheath is maintained up to the jack.

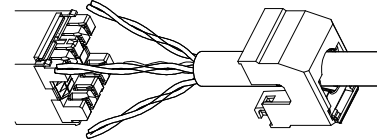

Fig. 3b.

3c. Punch down with 110 tool.

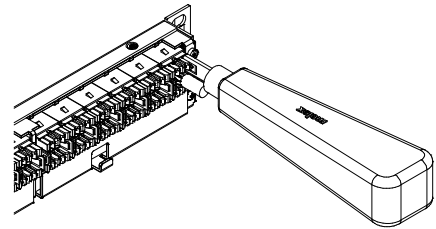

Fig. 3c

4. Stuffer Cap

Install stuffer cap.

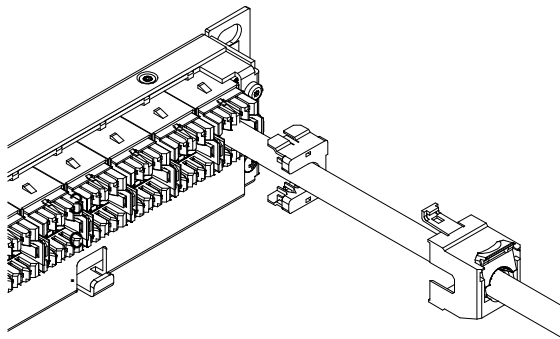

Fig.4

5. Fitting Rear Housing

Attach housing and close cable clamp. Clamp must contact drain wire wrapped around the cable.

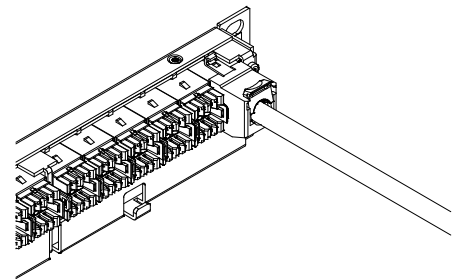

Fig.5

MPN NO.	SAP NO.
215-390	187000372

REVISION: A	ECR/ECN INFORMATION: EC No: MTS2012-0032 DATE: 2013 / 01 / 21	TITLE: Installation Instructions PID-00231 MIIM Category 6A Patch Panel	SHEET No. 3 of 4
DOCUMENT NUMBER: AS-18700-059	CREATED / REVISED BY: BJ Mahendra	CHECKED BY: CG Raghavan	APPROVED BY: Samuel Huber

6. Cable Dressing

- 6a. Install cable management tray to panel.
- 6b. Press cables neatly on cable management tray and secure with cable ties or Velcro strips ensuring 29 mm bend radius is maintained.
- 6c. Individually earth each panel to cabinet earth position.

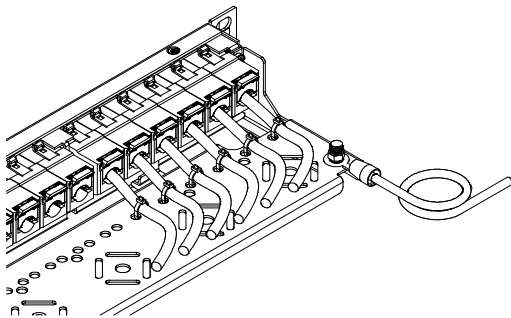

Fig.6

7. Attach MIIM I/O cable to I/O port

Secure to cable management tray if desired.

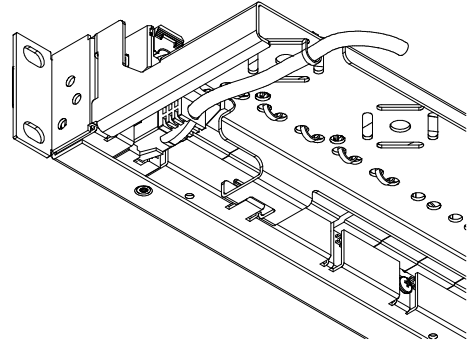

Fig.7

8. Removal Instructions

To remove rear housing, open clamp and pull up on latch on top of the housing.

Note: Use flat screwdriver to lift latch of housing.

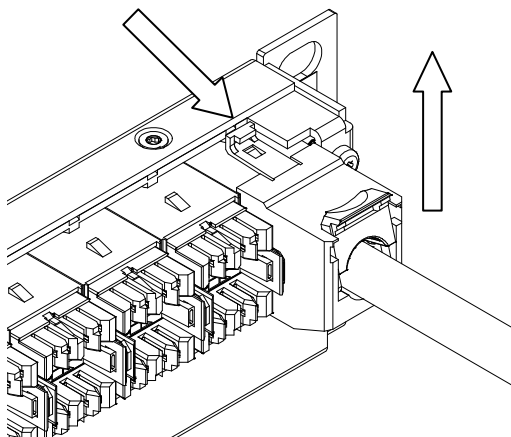

Fig.8

9. Adding MIIM panels to the MIIM System

Connect a patch cord between the RJ45 port on the back of the panel to a port on a MIIM scanner.

Refer to the scanner and panel firmware update section in the MIIM Installation Guide to insure the panel firmware and scanner application are matched correctly.

Access the scanner to confirm scanner application and panel firmware versions.

If necessary, perform a panel firmware update on the panel.

MPN NO.	SAP NO.
215-390	187000372

REVISION: A	ECR/ECN INFORMATION: EC No: MTS2012-0032 DATE: 2013 / 01 / 21	TITLE: Installation Instructions PID-00231 MIIM Category 6A Patch Panel	SHEET No. 4 of 4
DOCUMENT NUMBER: AS-18700-059	CREATED / REVISED BY: BJ Mahendra	CHECKED BY: CG Raghavan	APPROVED BY: Samuel Huber