

INSTALLATION INSTRUCTIONS FOR FLAT PACK CABINETS (24U/42U/45U/47U/52U)



ALL PRODUCT IMAGE'S SHOWN FOR REPRESENTATION PURPOSE ONLY

1.0 Scope

This document provides information on installation instruction of cabinets.

2.0 Procedure

Necessary tools for assembly.

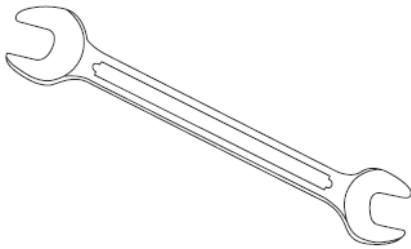

Wrench 19 & 27

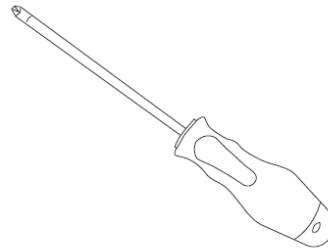

Screwdriver PH3

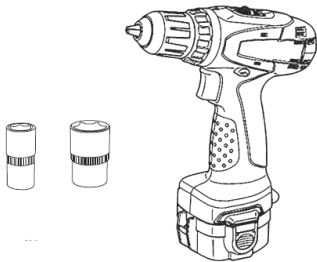

Socket wrench SW10 and 8
and electric screwdriver

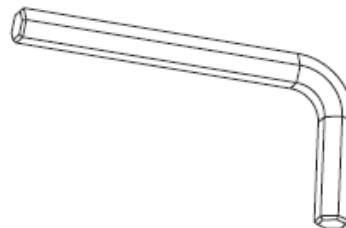

Hex key 8

ENGINEERING RECORD
NO: 756298

SAP NO: 187000540

Doc No: 187000540 Doc part: AS

REV- B

<http://www.molexces.com/>

Frame assembly -list of elements

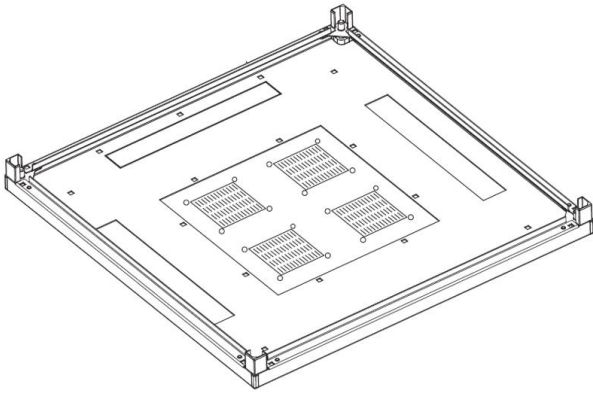

Frame's Top Plate

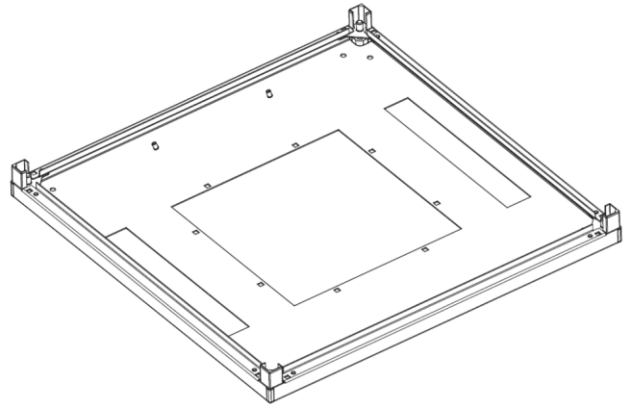

Frame's Bottom Plate

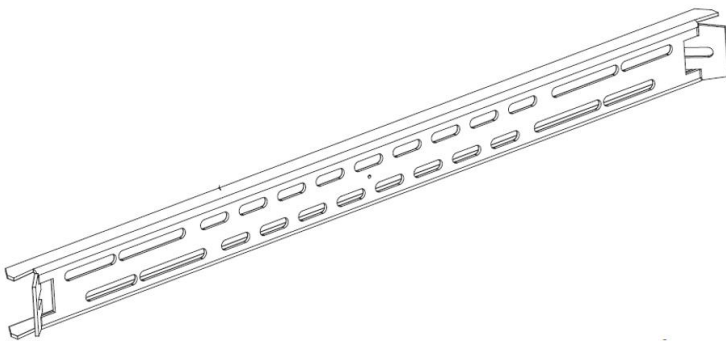

C -Profiles

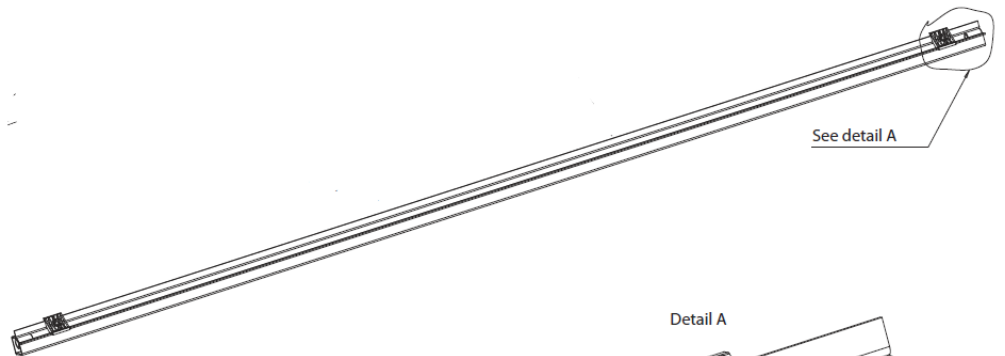

See detail A

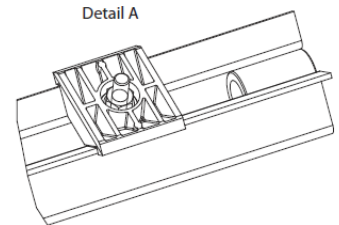

Detail A

Frame's Post

Frame's mounting directions

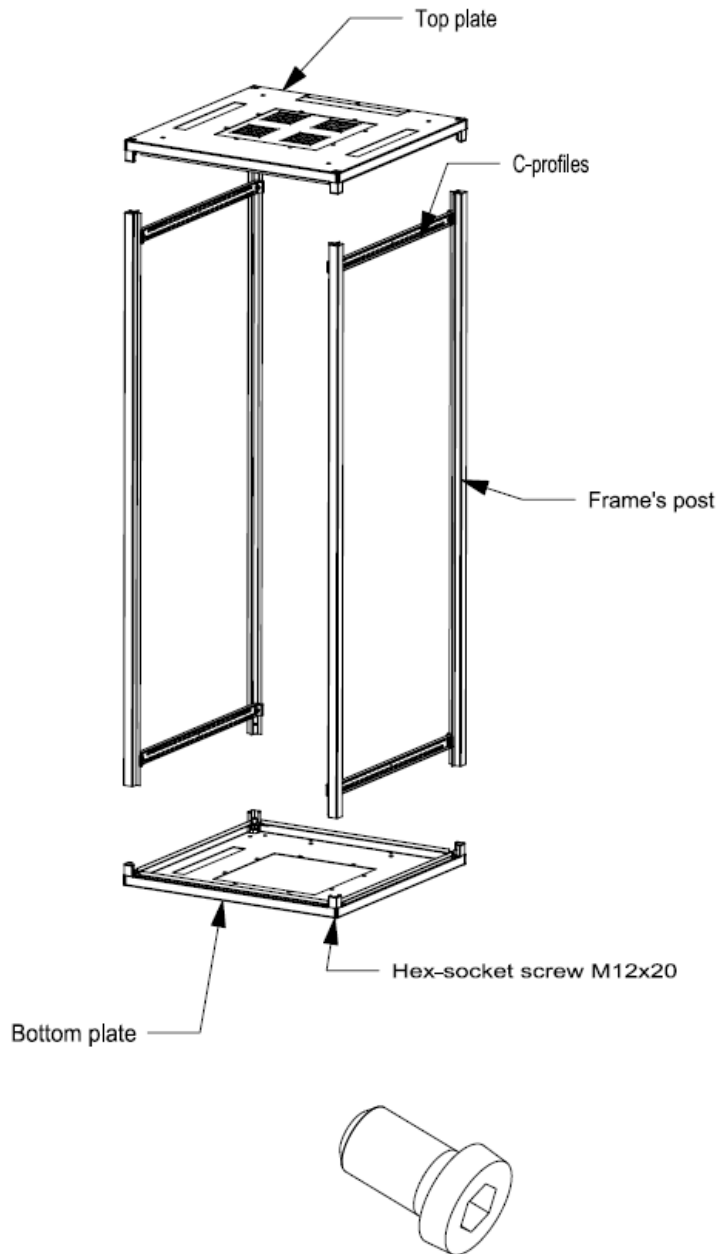

Screw should be pre-installed in bottom and top plate.

Cabinets manual assembly procedure.

Step 1: Mount the frame's post Qty (4) in to the Bottom plate.

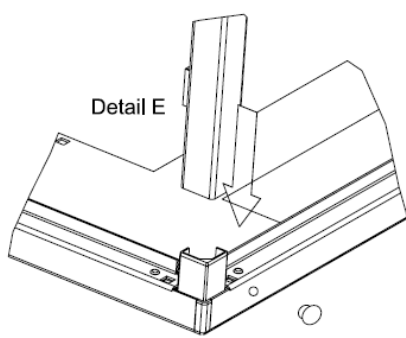
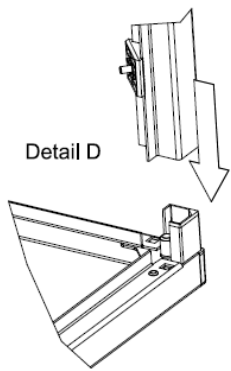
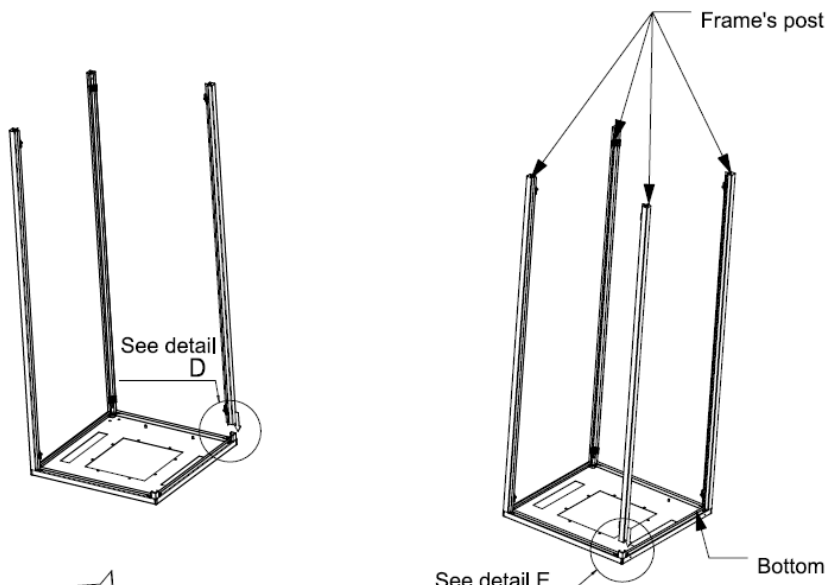
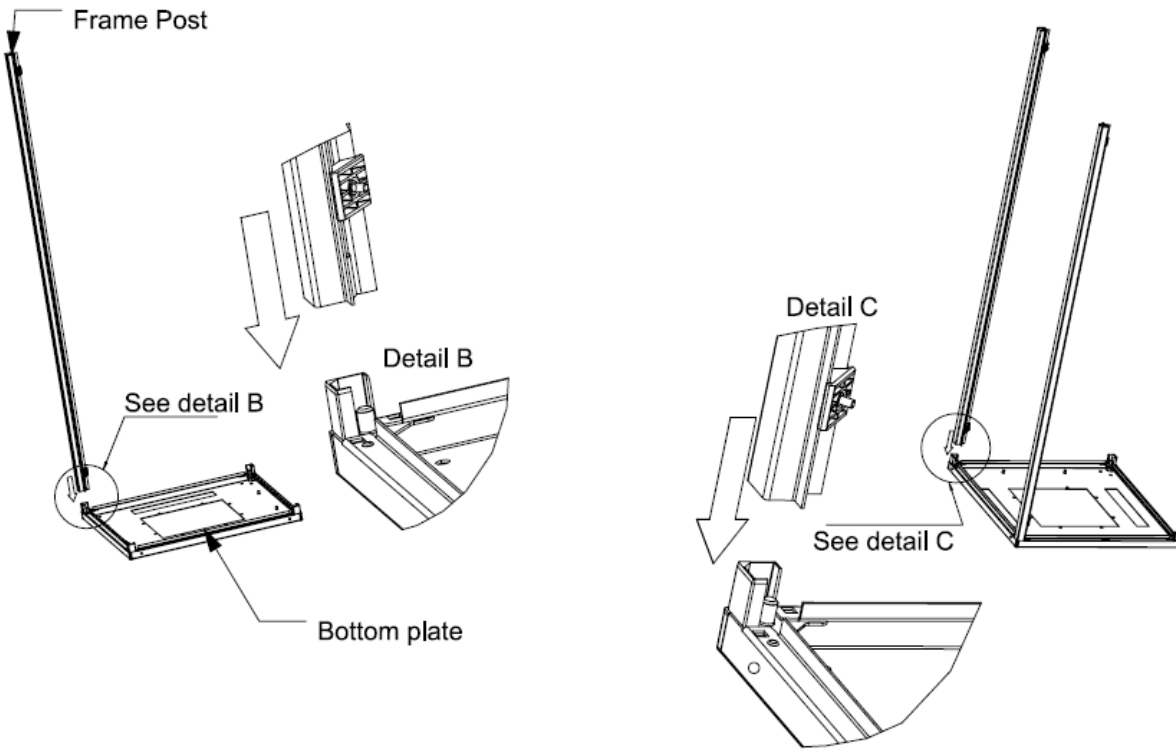

Step 2: Mount the Top plate to the frame's post as shown in the below.

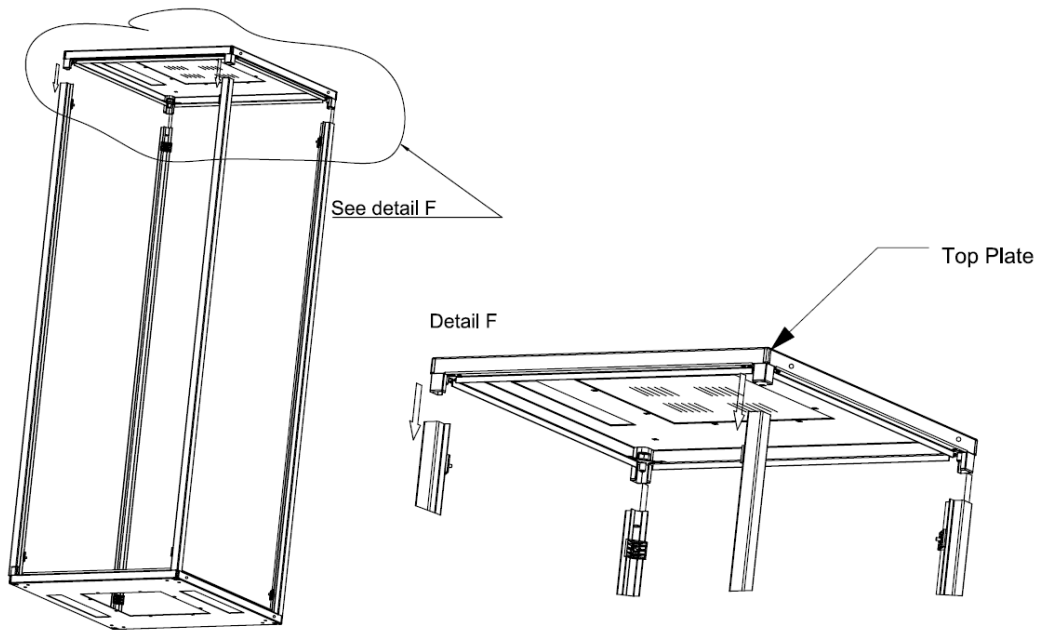

Step 3: Screwing the frames and fixing of the C-profiles - 600 or 800mm deep cabinets using hex key 8.

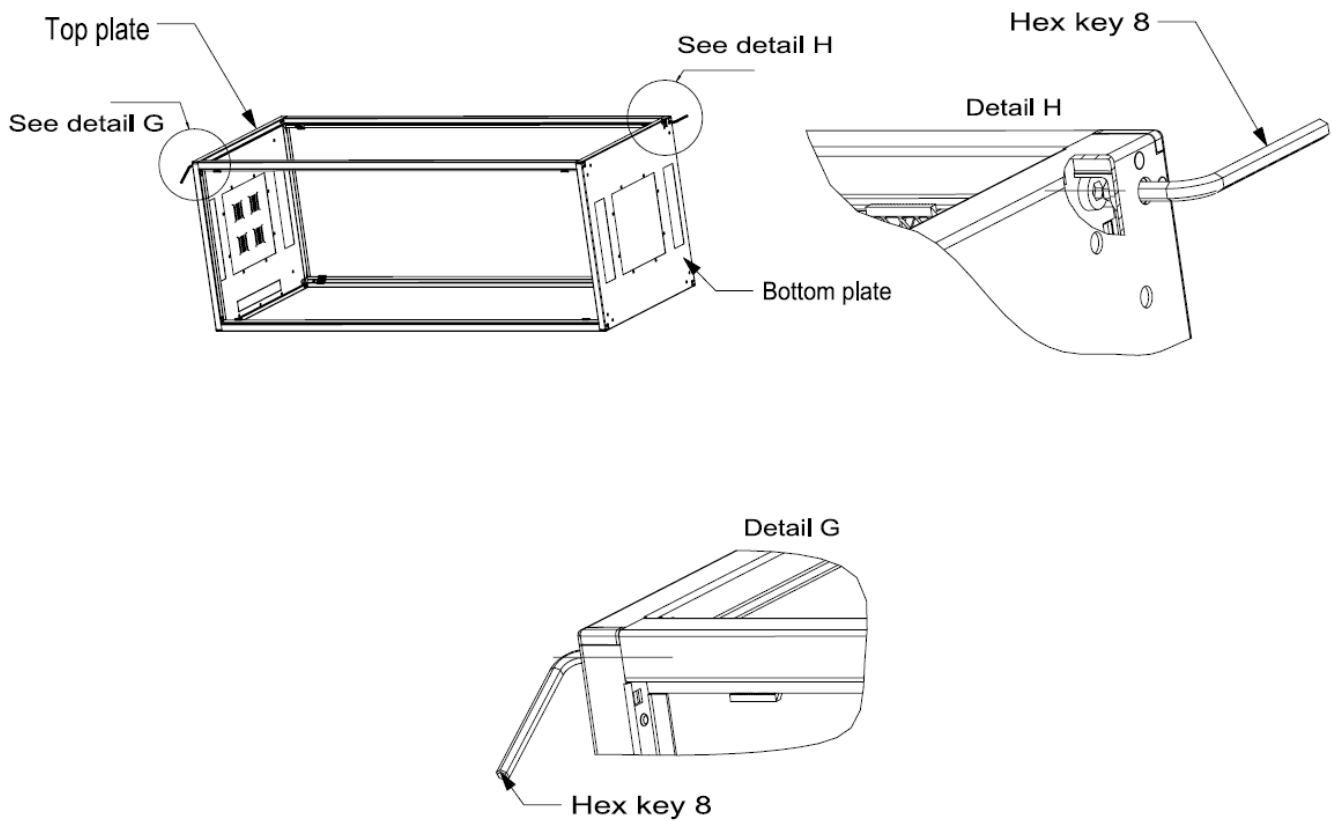

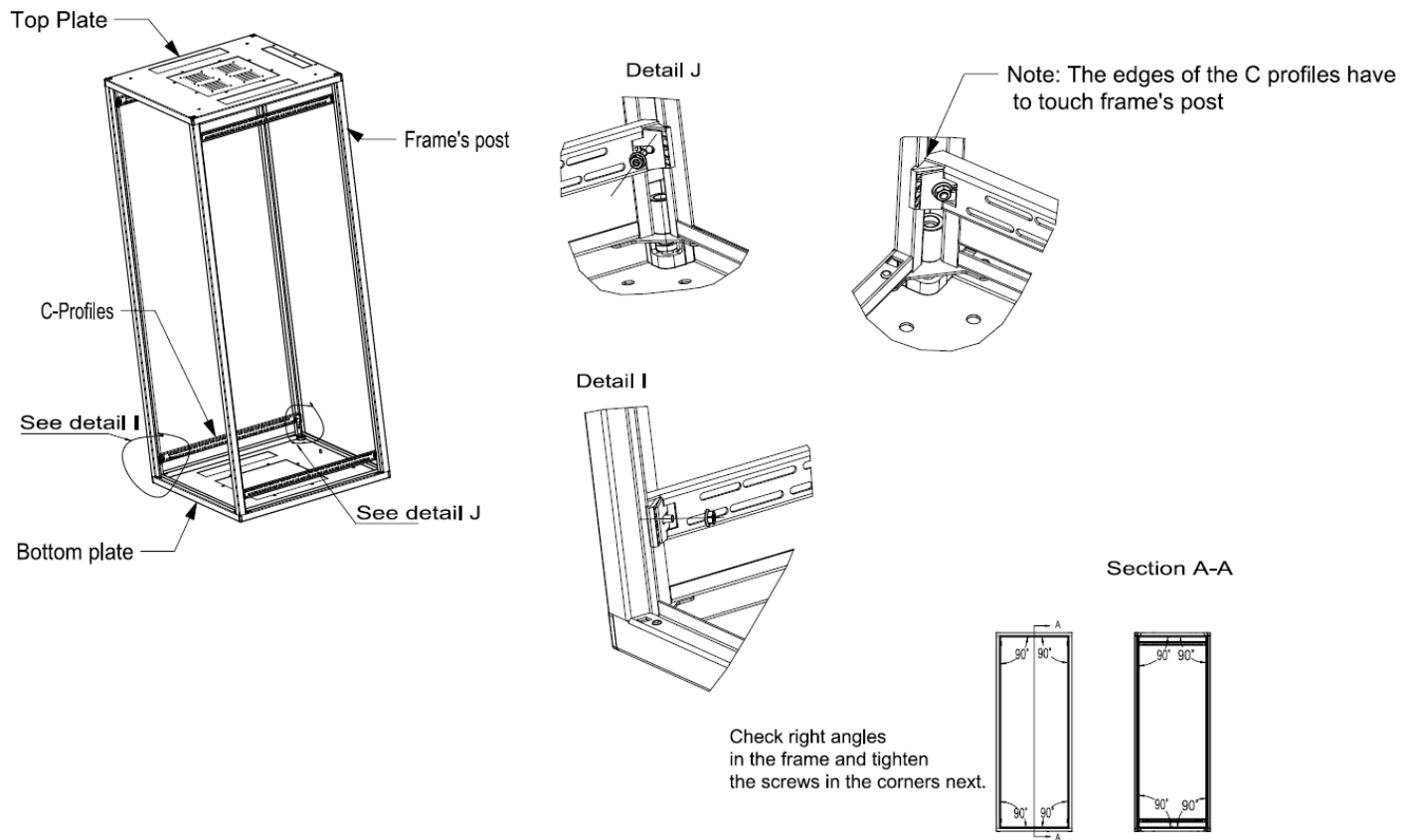

Screwing the frames and fixing of the C-profiles- 1000mm deep cabinets using hex key 8.

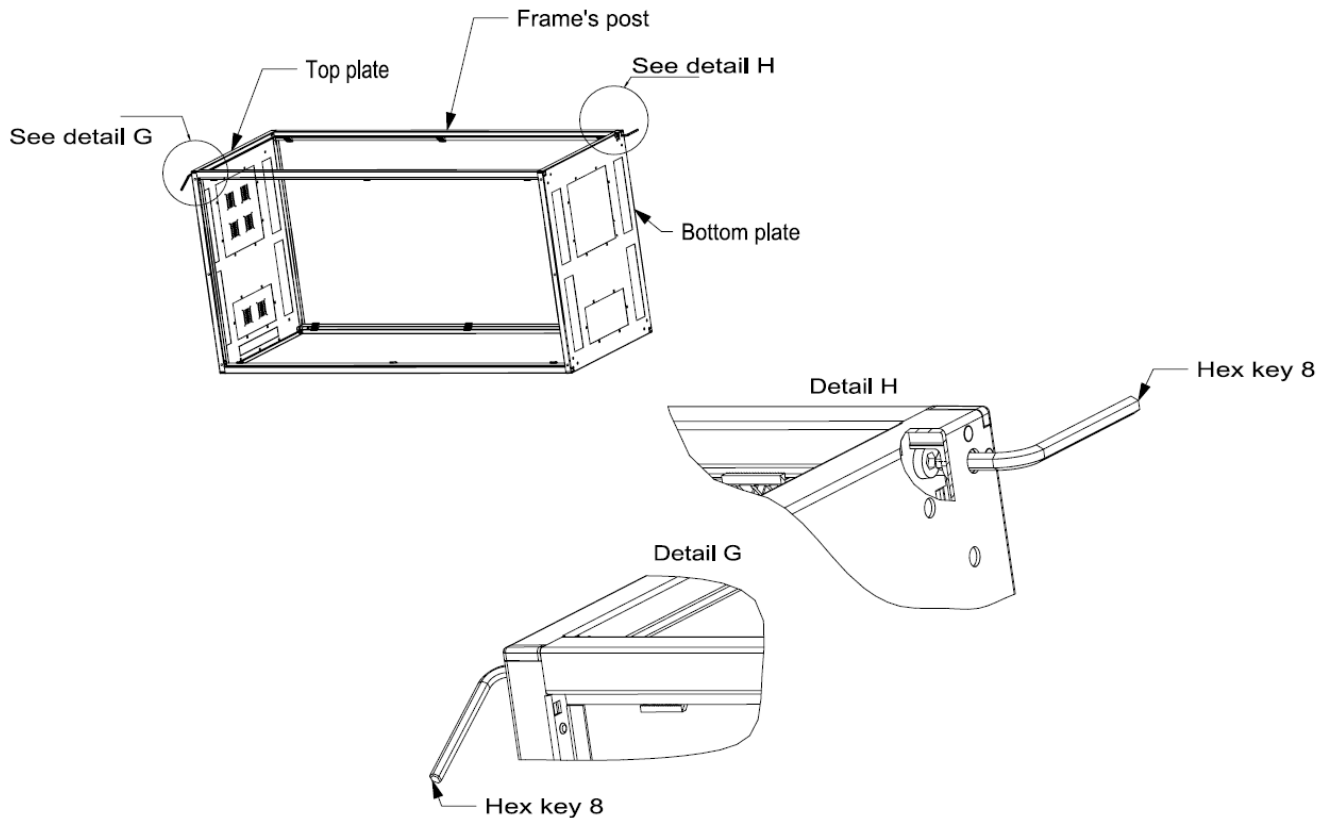

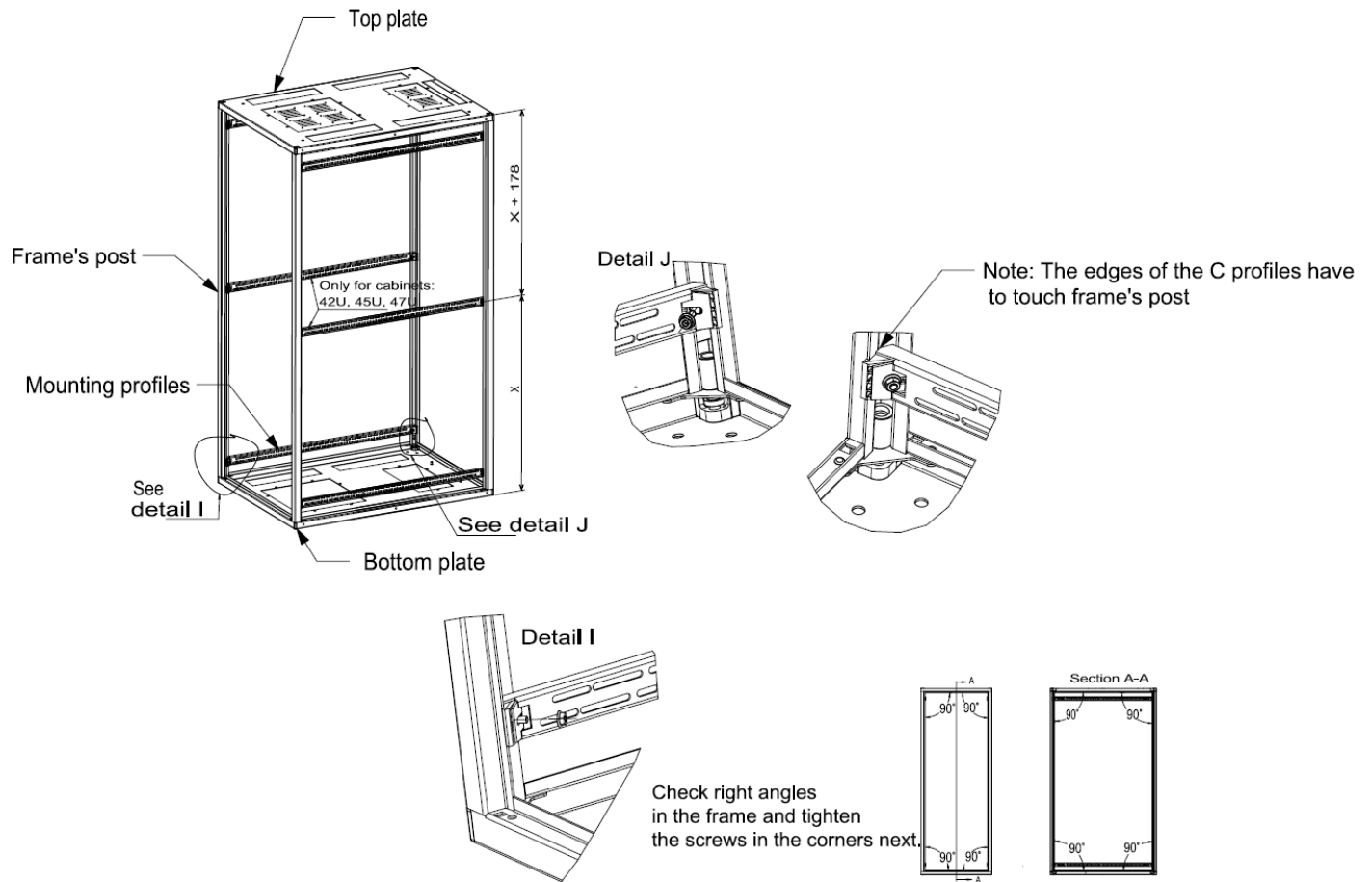

Step 4: Fix the levelling feet as shown in below using wrench 19. (For levelling cabinets refer page 9).

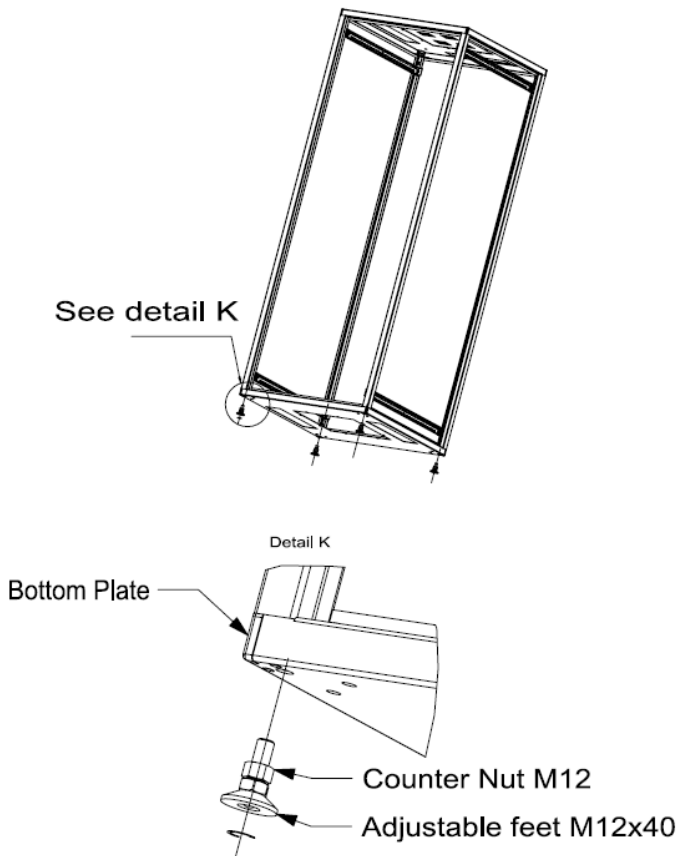

Step 5: Fixing & Screwing of the mounting profiles in 600mm or 800mm wide cabinets.

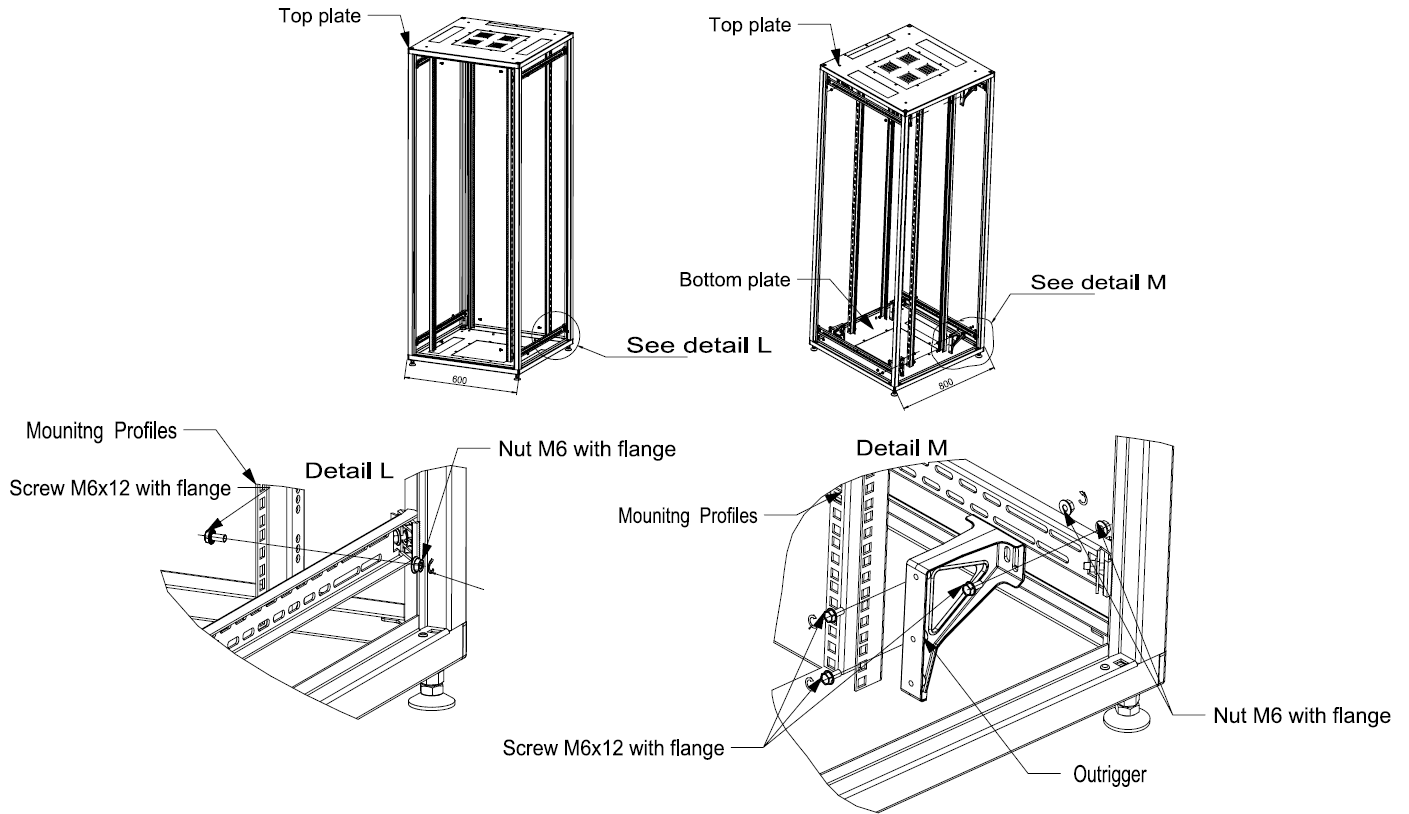

Step 6: Fix the side panels by using lock and lock nut.

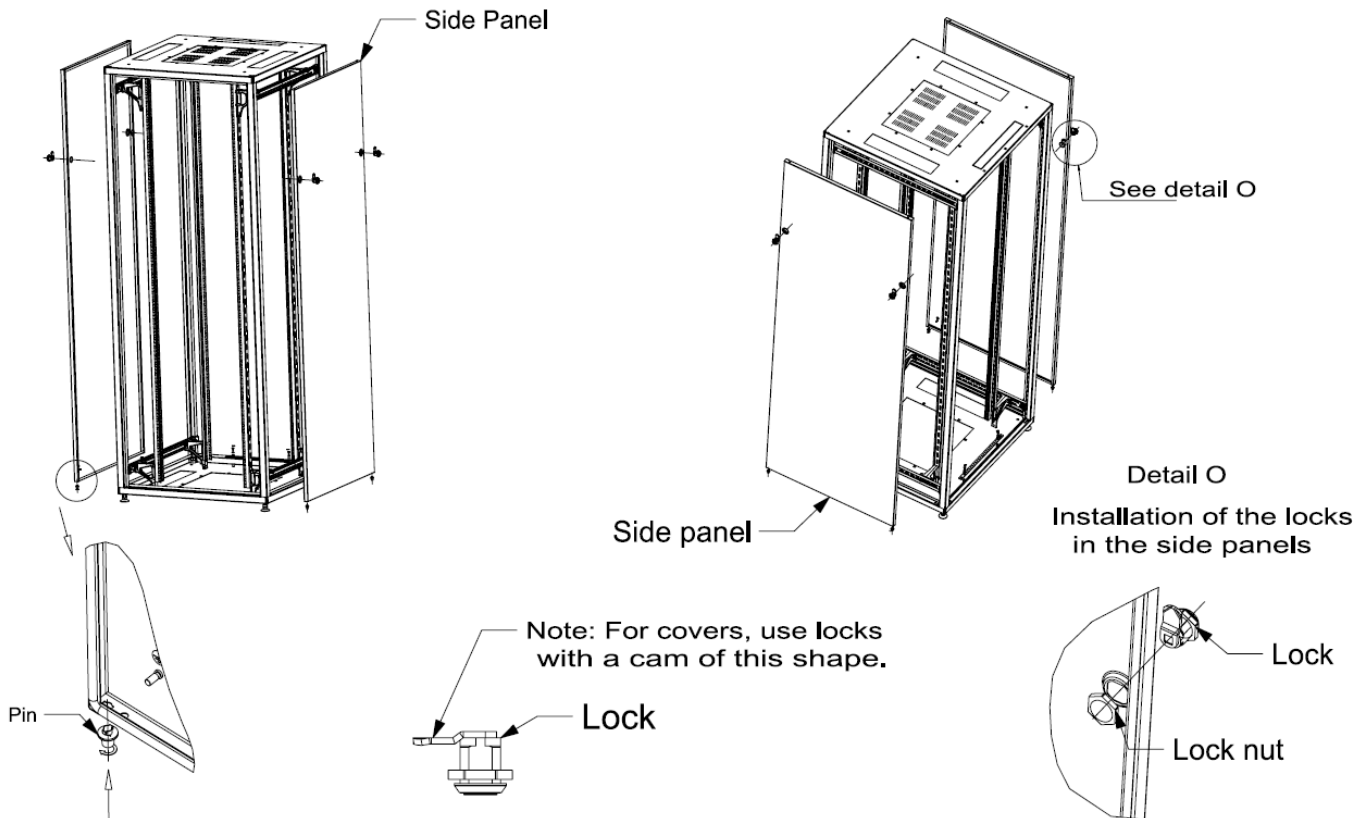

Step 7: Fix the Doors with 180° by Hinges, Screws & Mounting rivets.

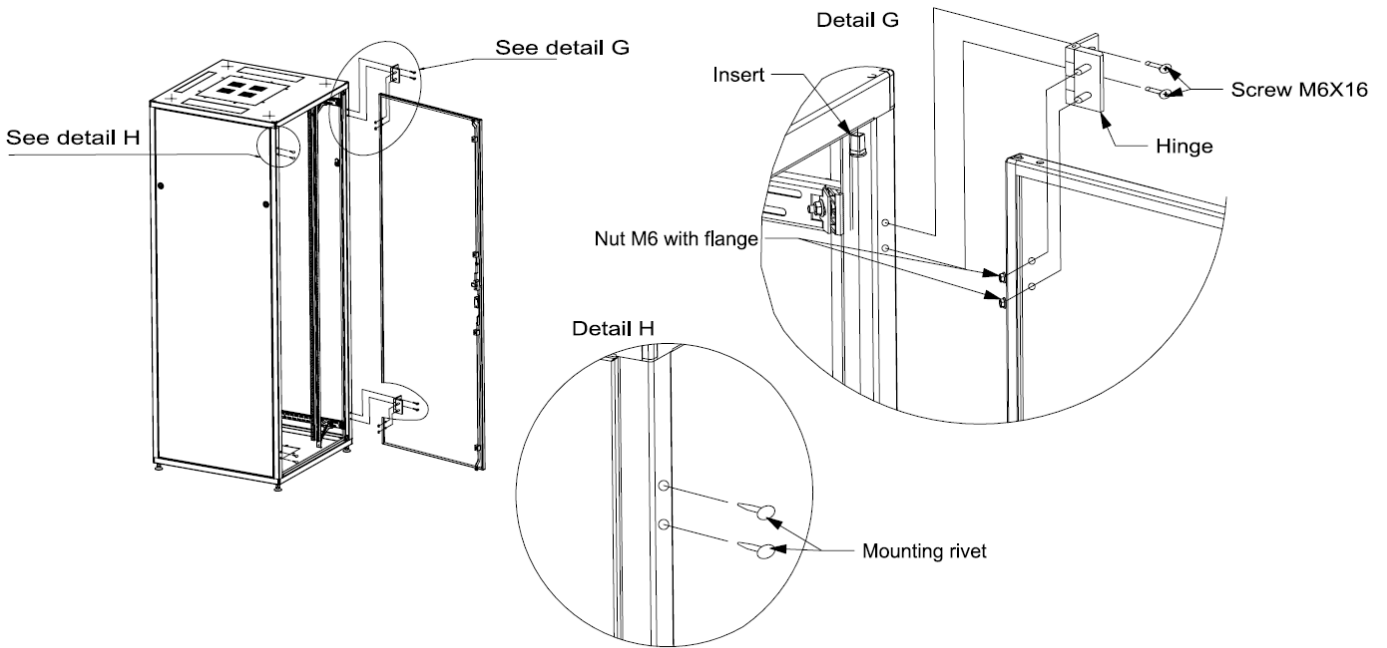

Step 8: Fix the Rear Door with 110° Hinges & 3U Module panel with the brush strip by using Pivots, Rivets, Inserts, Pin & circlips.

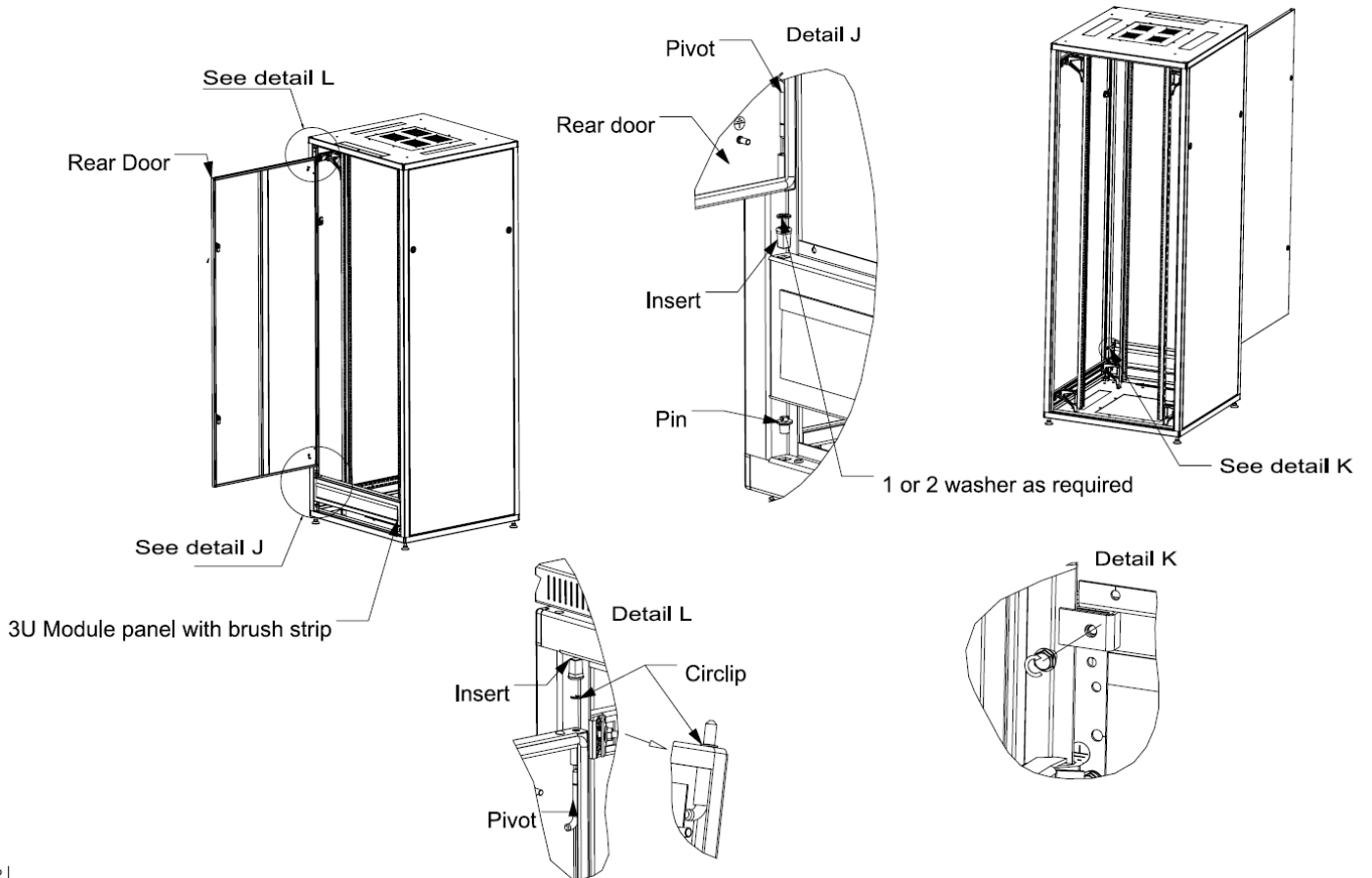

Step 9: Fix the Earthing cables as shown in below.

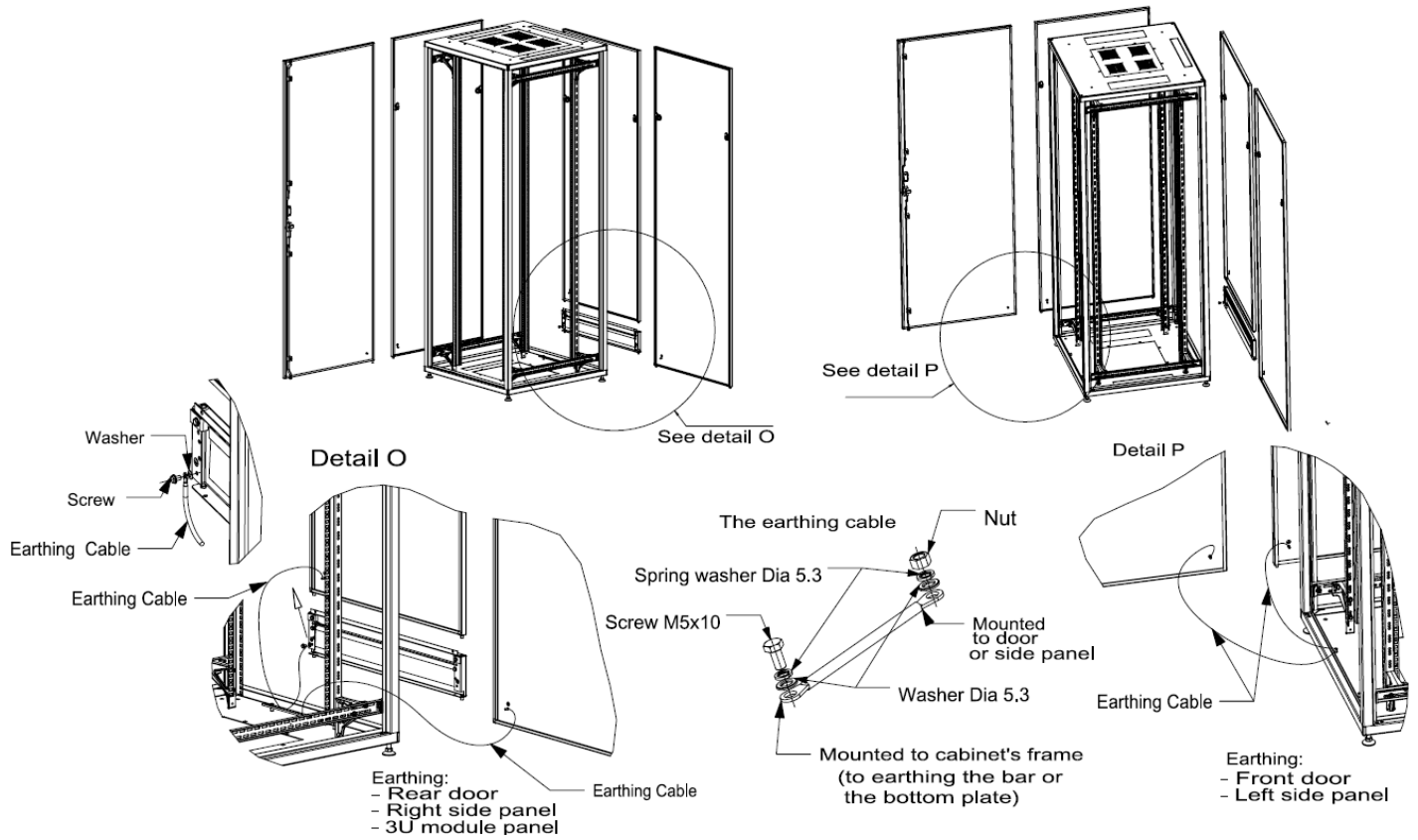

Step 10: Levelling the cabinets using levelling feet. After levelling the cabinet, tighten the nuts using wrench 19 to the cabinets bottom plate.

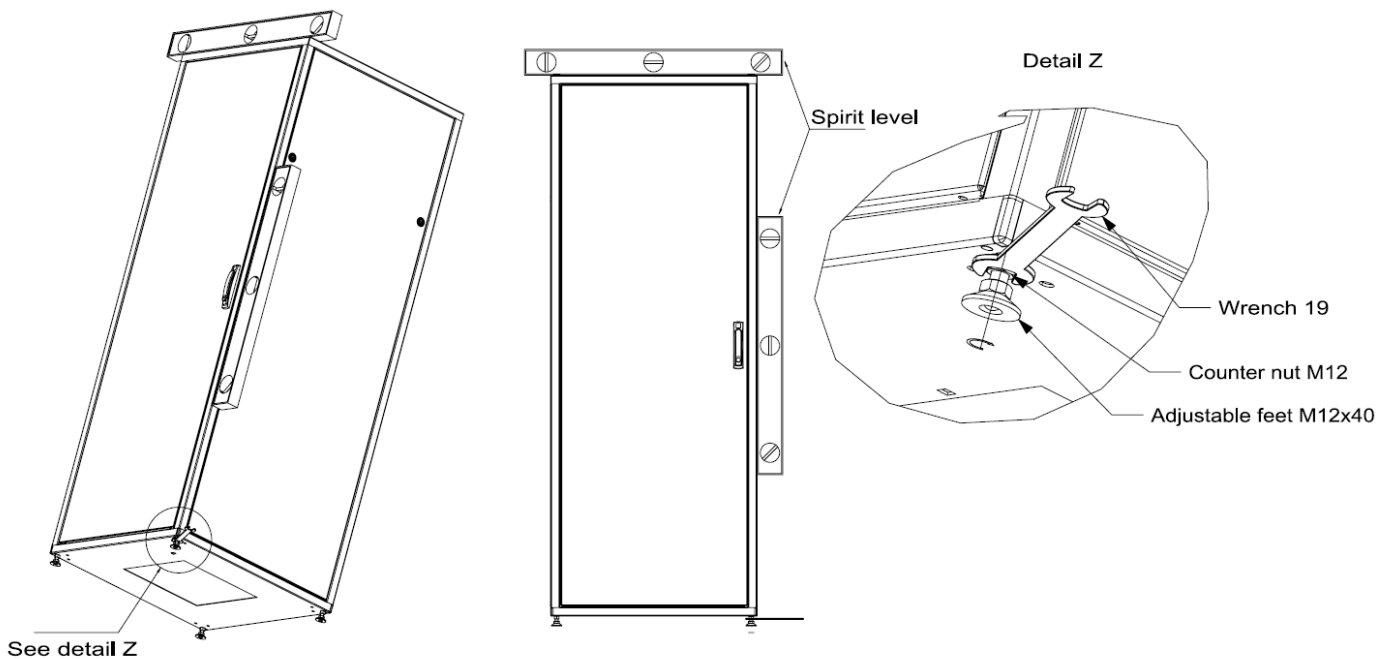

Step 11: When using VRM organizers, slide the front guides back (approximately from 110 to 200mm).