

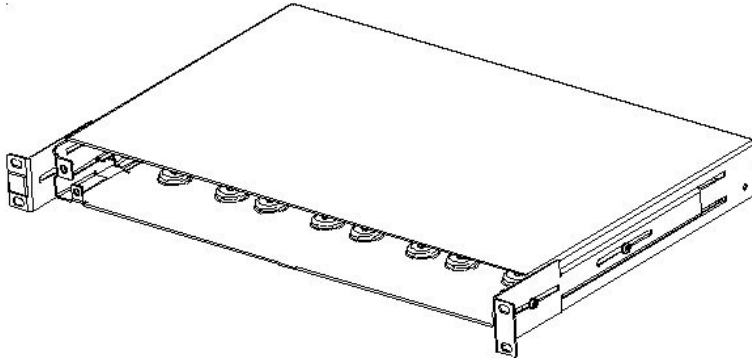

Fibre Management Panel (FMP 3) Body Kit



The FMP 3 is a 1U high universal fibre optic patch panel, accommodating up to 48 fibres. When installed in a 19" rack, the FMP 3 provides organisation and protection of optical fibres. The FMP 3 can be used as both a sliding and fixed panel.

1. Fix front plate to the tray using the 2 black screws supplied in the accessory kit (M4 x 6).
2. Choose installation position within the cabinet.
3. Depending on your requirement, adjust position of side brackets.
4. Insert cable management clips in the required position into the tray as shown below.
Note: 8 cable management clips are included in the accessory kit supplied with the base. The base accepts up to 16 cable management clips (for 48 fibres). Additional cable management clips can be purchased separately in packs of 8, (p/n KFR-00033).

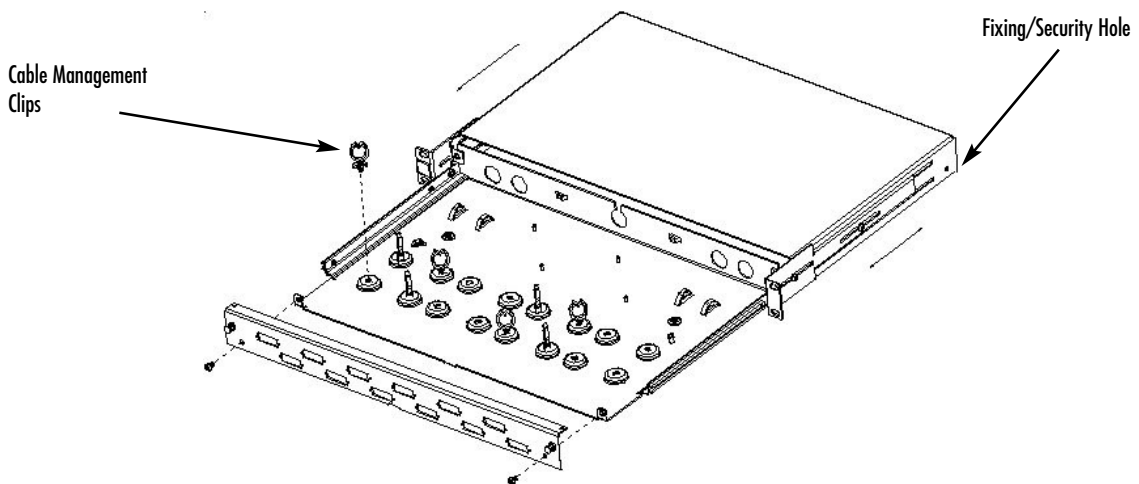

MOLEX PREMISE NETWORKS

Molex Premise Networks
Corporate Headquarters
 Tel: 1 866 733 6659
 www.molexpn.com

European
Headquarters
 Tel: 44 (0) 1489 572111
 www.molexpn.co.uk

Pac Rim
Headquarters
 Tel: 61 3 9971 7111
 www.molexpn.com.au

Molex
Incorporated
 Tel: 630 969 4550
 www.molex.com



Fibre Management Panel (FMP 3) Body Kit

5. Install cable gland in the appropriate hole at the rear of the panel, and blanking plugs in any unused holes.
NOTE: The glands and blanking plugs are included in the accessory kit supplied with the base.
6. Feed cable into gland and panel with sufficient slack for a "swan neck", to allow panel or tray to be worked on. Mark the cable jacket for stripping. The jacket should be removed approximately 40mm from the cable gland fixing. Secure cable jacket at the tie down points, using cable ties.
NOTE: This measurement is to be used for 900um buffered fibres. If outside plant cable is used, and a breakout kit is to be installed, the cable should be positioned accordingly. Each breakout kit is different, select a cable mounting position that will allow you to secure the cable and kit without violating the fibre minimum bend radius of 40mm.
7. Secure aramid yarn in the kevlar retention clamps.
NOTE: The FMP 3 accepts up to two kevlar retention clamps, one of which is included in the accessory kit supplied with the base, additional clamps can be ordered separately (p/n KFR-00034).
8. Install the fibre terminations according to the connector manufacturer's instructions. The fibre storage capacity of the FMP 3 will allow you to leave enough slack fibre length to bring the ends to a convenient work area for termination. Once the terminations are complete, clean the connectors and plug them into the adapters.
NOTE: Adapters are not supplied with the unloaded front plates, but can be supplied separately. Contact Customer Services for more information and part no detail.
9. If the splice option is used, locaton studs for 2 x fusion splice holders (p/n AFR-00190) can be found at the back of the tray.
NOTE: Molex Premise Networks recommends the short splice protector (45mm) when using this panel (p/n KFR-00008)
10. Insert the 2 screws (M4 x 16) at each side of the base, towards the rear for fixed/secure option.

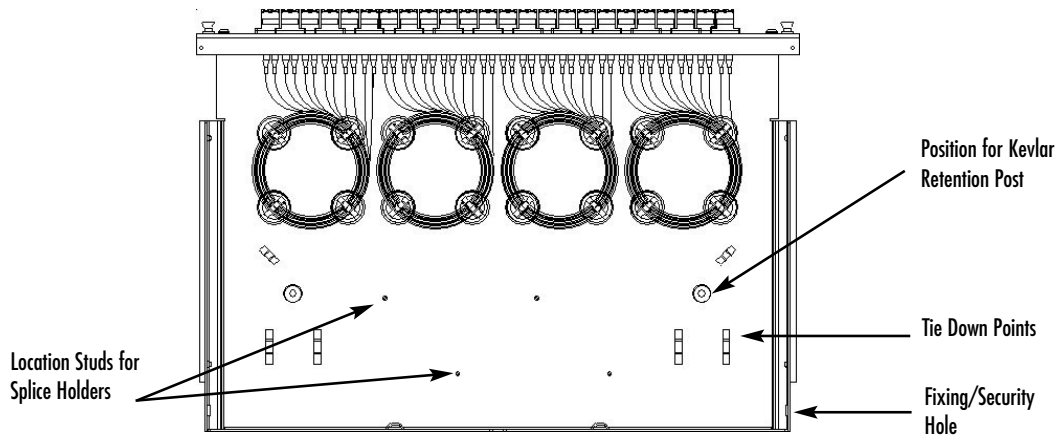

MOLEX PREMISE NETWORKS

**Molex Premise Networks
Corporate Headquarters**
Tel: 1 866 733 6659
www.molexpn.com

**European
Headquarters**
Tel: 44 (0) 1489 572111
www.molexpn.co.uk

**Pac Rim
Headquarters**
Tel: 61 3 9971 7111
www.molexpn.com.au

**Molex
Incorporated**
Tel: 630 969 4550
www.molex.com