

STREAMLINE WALLPLATE INSTALLATION INSTRUCTION

1.0 SCOPE

This document will describe the installation instructions for straight 1P, 2P, 4P & Angled 1P,2P Streamline wall plates.

2.0 PROCEDURE:

2.1 ASSEMBLY INSTRUCTIONS

2.1.1 1P WALL PLATE:

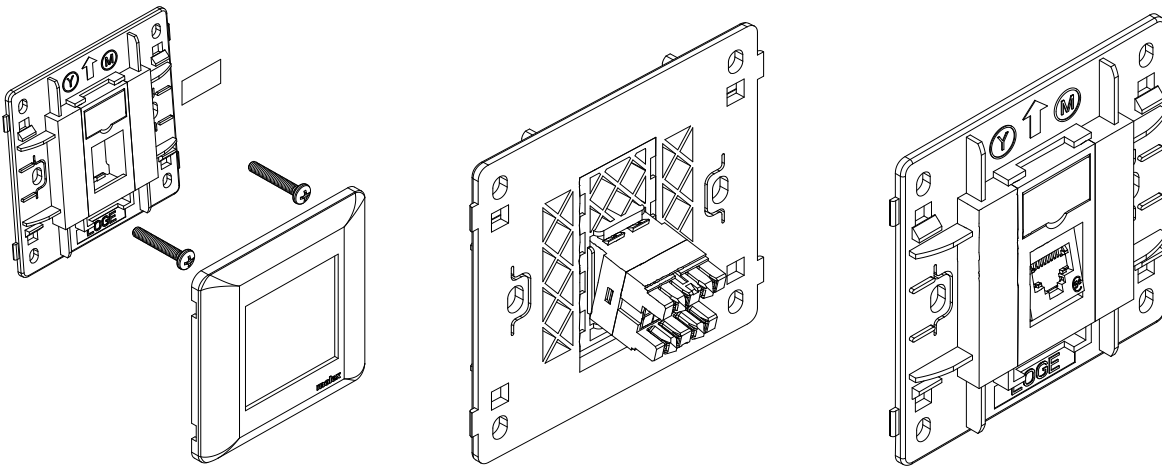

FIG. 1

2.1.2 2P WALL PLATE:

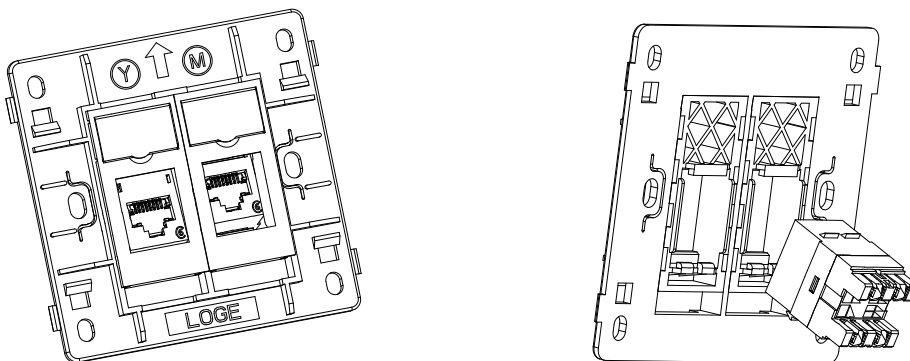

FIG. 2

ENGINEERING RECORD NO: 630008	SAP NO: 187000426	Doc No: AS-18700-120	Doc part: AS	REV- B
http://www.molexces.com				

2.1.3 4P WALL PLATE:

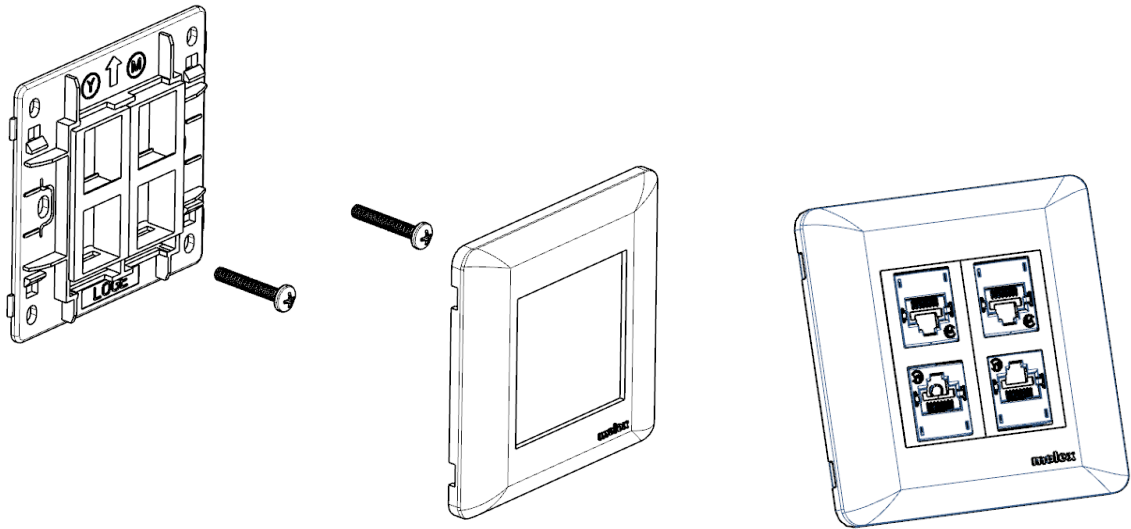

FIG.3

2.1.4 1P ANGLED WALL PLATE

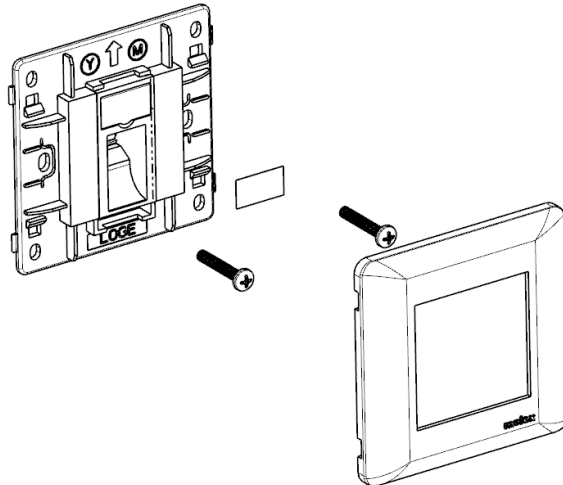

FIG.4

2.1.5 2P ANGLED WALL PLATE

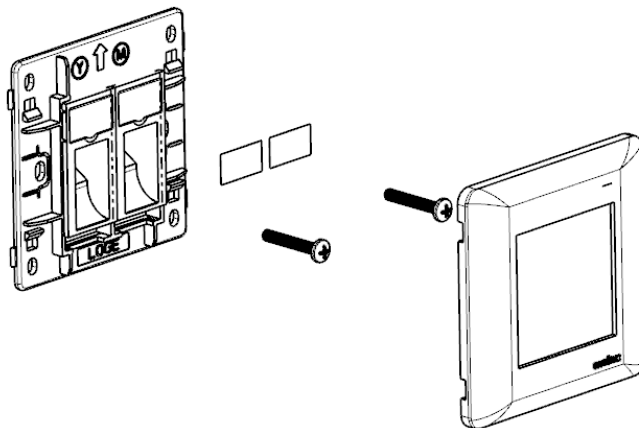
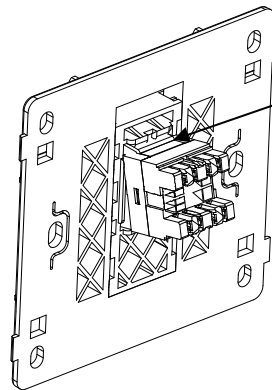

FIG.5

2.2 ASSEMBLY INSTRUCTIONS FOR ALL THE WALL PLATES (FIG. 1, 2,3,4 & 5):

1. Hold the wall plate so the arrow on the base is pointing up.
2. Install the jack from the back of the wall plates - engage the two latches at the bottom of jack with the latches provide in the Wall plate jack holder and press it until you get click sound
3. Mount the wall plate using screws.
4. Put the wall plate cover to the base.
5. Insert the wall plate label inside the label holder and lock it (Not applicable for 4P wall plate).

2.3 REMOVAL INSTRUCTIONS (FIG.4):



Insert the small screwdriver here

FIG.4

1. Place the tip of a small screwdriver between the large tab and the edge of the plate and gently pry upwards.
2. Lift the jack up

2.4 FIXING THE WALLPLATE ON THE WALL / GANGBOX

1. Remove the cover from the Wall plate.
2. Fix the screws provided with the pack and screw it tight to the wall / gang box.
3. Fix the frame back on the Wall plate.