



C6A CONSOLIDATION POINT BOX SHIELDED -568A/B

Note: Refer to page 5 installation instructions design for Generation-1 DataGate Jack design (part no KSJ-00062-**))

1.0 SCOPE







This document provides Installation Instructions of C6A Consolidation point box FTP-568A/B

2.0 PRODUCT DESCRIPTION

Consolidation Points or Multi-User Telecommunications Outlets (MUTO) are intended to provide increased flexibility and economy for installations where open office spaces require frequent reconfiguration.

3.0 PROCEDURE

3.1 TOOLS REQUIRED:

 <p>Molex 4 Pair Termination Tool - (31.0011) Lacing Head (31.0015) (Recommended)</p>	 <p>Wire Cutter</p>	 <p>Cable Stripper</p>
 <p>Flat Screwdriver</p>	 <p>Needle Nose Plier</p>	 <p>110 Punch down tool</p>

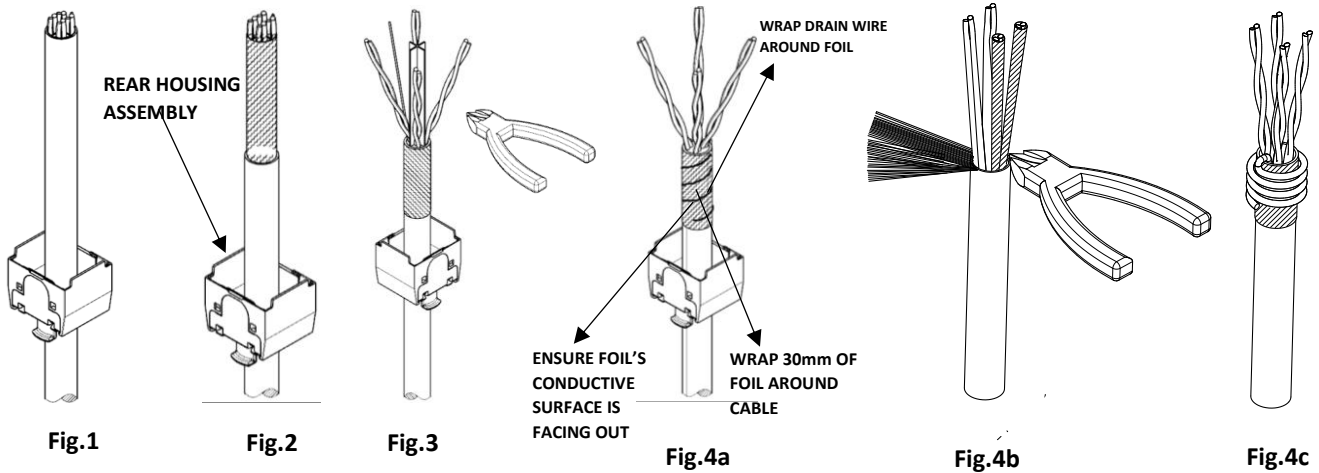

3.2 U/FTP Cable preparation:

- Slide Rear Housing on to cable (see Fig. 1)
- Remove 75mm (3") of cable sheath with cable stripper (see Fig. 2)
- Unwrap and remove 3 of the twisted pair's foils with wire clippers.
- Wrap approx. 30mm (1.2") of 4th foil down the length of cable sheath and coil the drain wire on foil (see Fig.3 and Fig.4a)
 - Ensure cable foil's conductive surface is facing out.

F/UTP Cable preparation:

- Slide Rear Housing on to cable (see Fig. 1)
- Remove 75mm (3") of cable sheath with cable stripper (see Fig. 2)
- Unwrap overall foil from cable.
- Remove cable cellophane wrap and central spline with wire clipper (See Fig.3)
- Wrap approx. 30mm (1.2") of foil down the length of cable sheath and coil the drain wire on foil (see Fig. 4a)
 - Ensure cable foil's conductive surface is facing out.

ENGINEERING RECORD NO : 734103	SAP NO : 187000418	Doc No: AS-18700-112	Doc part: AS	REV- B1
http://www.molexcs.com				

S/FTP Cable preparation:

- 1) Slide Rear Housing on to Cable (see Fig. 1)
- 2) Remove 75mm (3") of Cable sheath with Cable stripper (see Fig. 2)
- 3) Carefully split the braid along one side. (See Fig.4b)
- 4) Remove shield from three pairs. Use clippers to cut-off foil. Pull the foil shield back from the fourth pair over the jacket and wrap the bundle of braid around the shield. Ensure cable foil's conductive surface is facing out. (See Fig.4c)

3.3 CABLE TERMINATION TO JACK:

1. Wiring map (see Fig. 5) Label affixed on jack IDC housing.

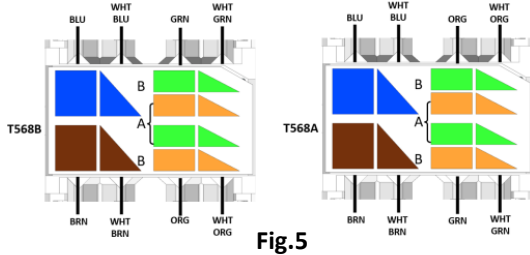

Fig.5

2. Untwist cable pairs and place the cables as per wiring map (Fig.6) and punch down wires to corresponding jack IDC contacts with 110 punch down tool (Fig.7). Molex also recommends 4-Pair Termination Tool (Fig.8) using Lacing head for termination.

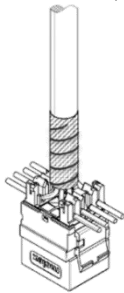

Fig.6

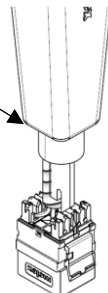

Fig.7

4-Pair termination tool

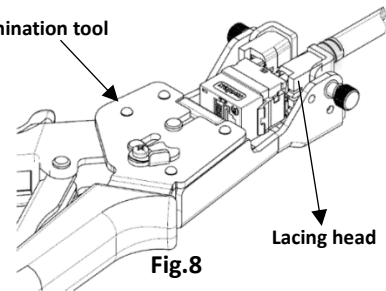

Fig.8

Lacing head

3. Ensure wires are trimmed flush to IDC towers
4. Ensure cable sheath is maintained up to the jack.

- 2.1 Fix the stuffer cap to IDC Housing (Fig.9) (Ensure Stuffer cap is locked perfectly with IDC Housing) and then slide down the Rear Housing till it is locked with IDC Housing 4 latches.

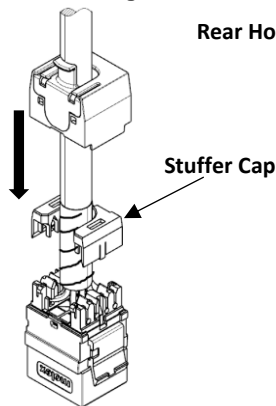

Fig.9

Rear Housing Assembly

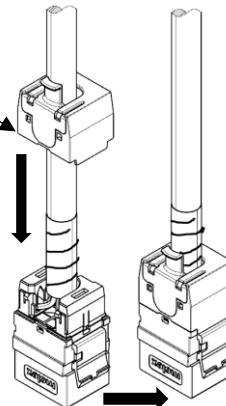

Fig.10

- 2.2 Position the cable grip over the rear housing. Secure the cable grip until it locks in place, using nose pliers

NOTE: Ensure drain wire or Twisted braid is touching with Cable clamp while fixing the Cable grip (Fig 11.a & Fig 11.b).

Note: Cable ties (Max. Width 2.5-3mm) can also be used to secure the clamp/drain wire & cable in place of cable grip as a choice.

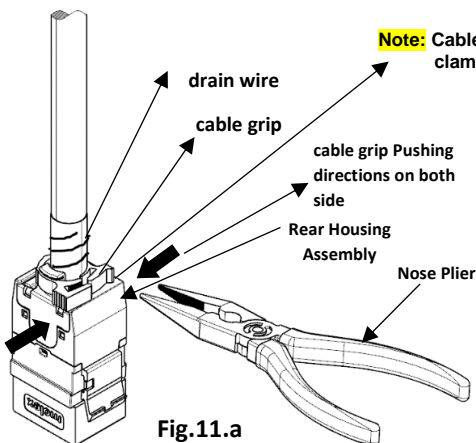

Fig.11.a

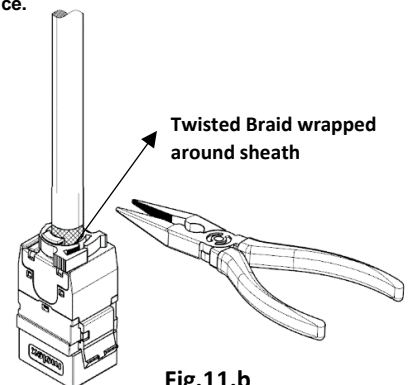
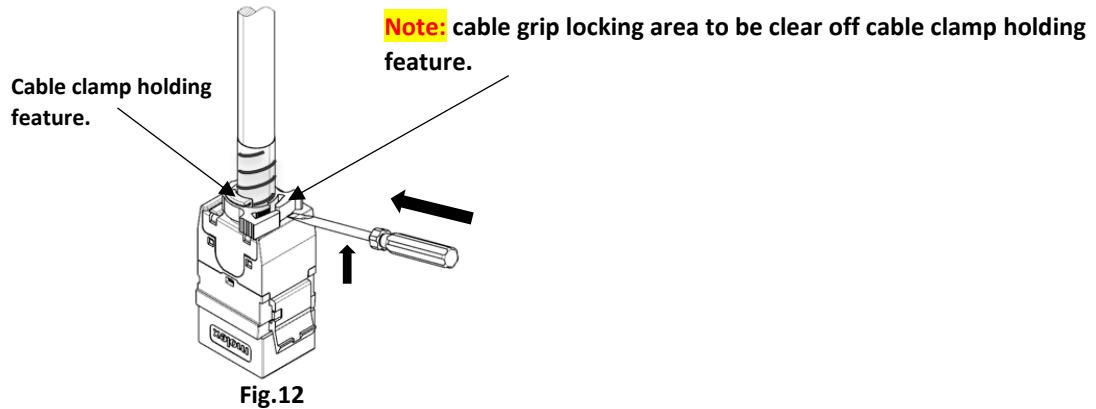

Fig.11.b

4.0 PROCEDURE TO REMOVE THE REAR HOUSING:

- A) To release the cable grip, use a screwdriver to lever to unlock Fig.12
- B) Cut the cable Ties with cutter if it used for tying the cable.



4.1 Insert needle Nose Plier into the Rear Housing slots and push both latches at a time then tilt the Rear Housing as shown (Fig.13) hold in that position and rotate the Jack 180° (Fig.14). follow same step on other side (Fig.15).

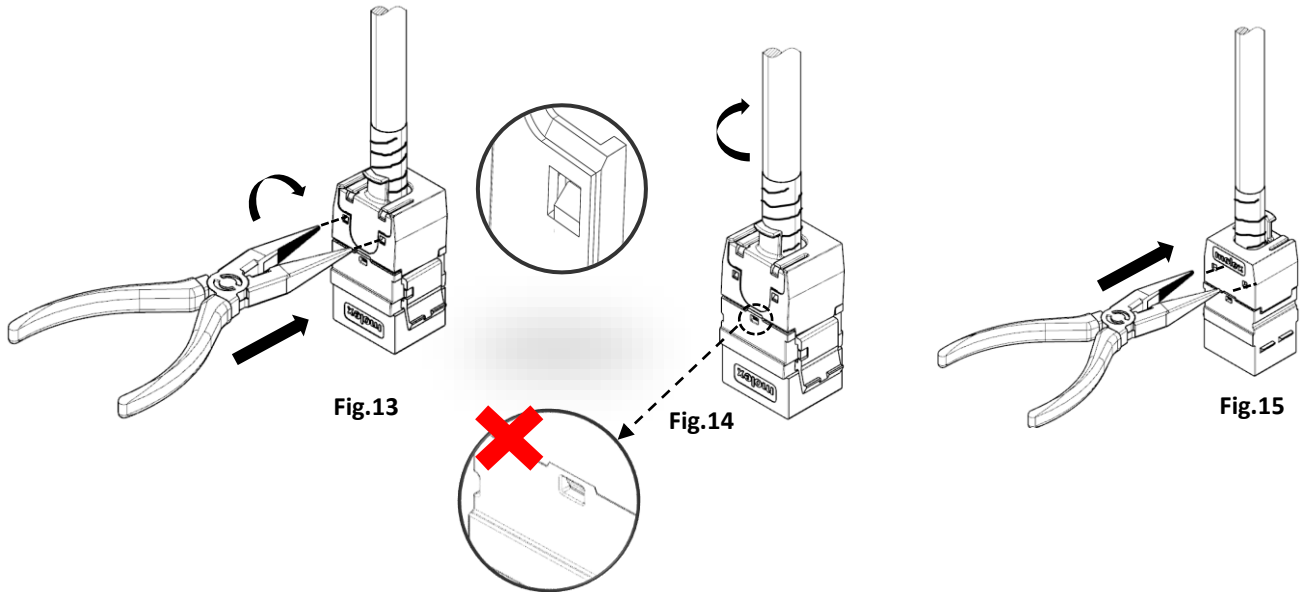

! Do not release this latch by inserting any tools here, as this will damage the product.

4.2 Insert the Screwdriver and gently lift the Stuffer cap latch and tilt stuffer cap as shown (Fig.16) and rotate the jack 180° and follow the same step (Fig.17) and remove stuffer cap (Fig.18 &19).

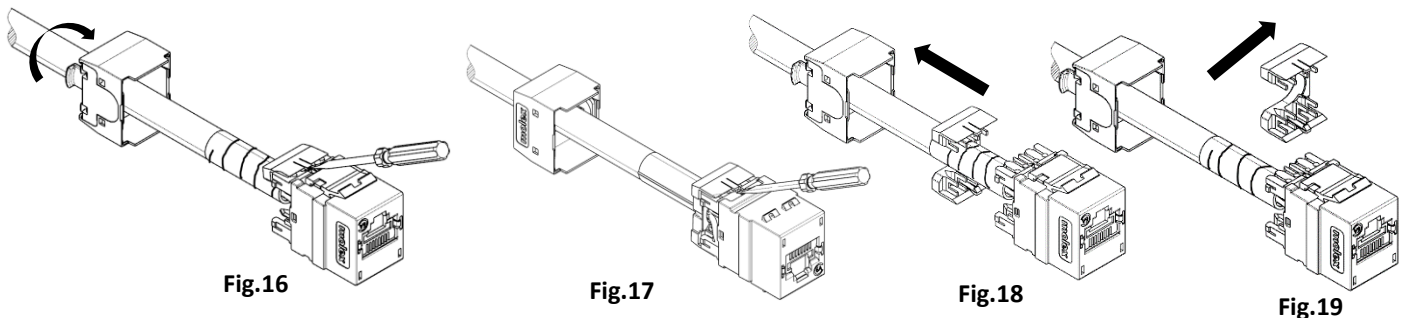

Video for Installation Guide with 110 Punch down Tool: <https://www.youtube.com/watch?v=B2TtatCDYt8>



5.0 TO ASSEMBLE JACK TO CONSOLIDATION POINT COVER:

1. Orientate jack into module fascia as shown in Fig. 20
2. Slide the jack into module port opening at slight angle (see Fig. 21)
3. Insert the jack latches into base of module
4. Snap jack into module fascia by pushing down on top of jack (see Fig. 21)

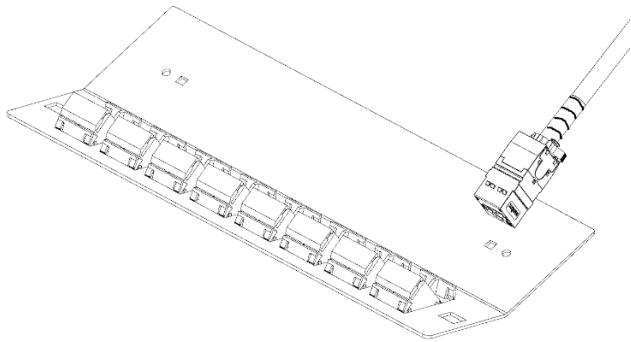

Fig.20

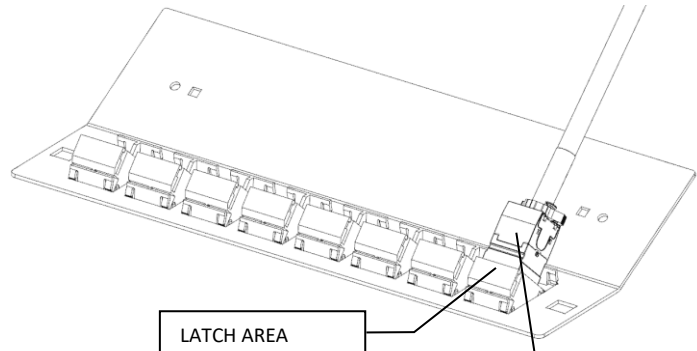

Fig.21

INSERT JACK AT SLIGHT ANGLE AND PUSH DOWN

6.0 ASSEMBLY AND CABLE DRESSING IN CONSOLIDATION POINT BOX

Dress cables

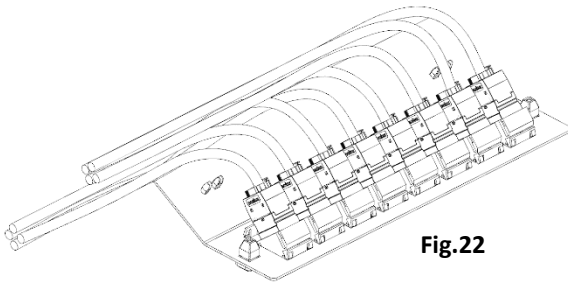
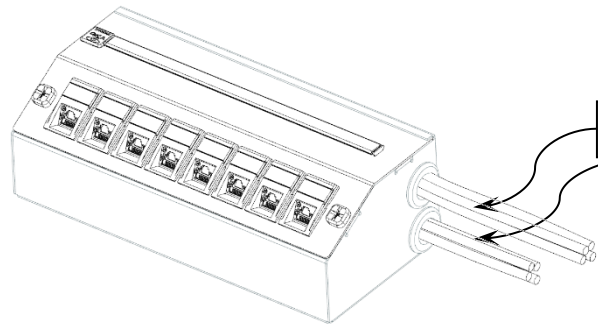

Fig.22



4 cables

Fig.23

1. Arrange the terminated cables as Fig-22
2. Pass 4 bundled cables through the grommet fitted cable exit hole. See Fig-25

Fit Cover to Base

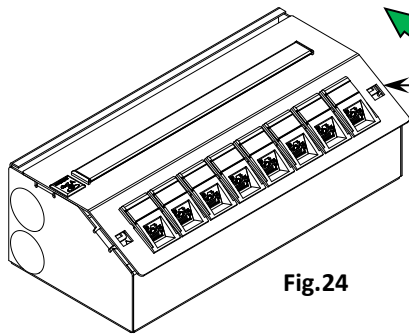

Fig.24

Slide the cover into the opening of Box in the direction of arrow

Secure Cover by locating the snap-fit fastening, turn through 45° and push firmly they snap shut.

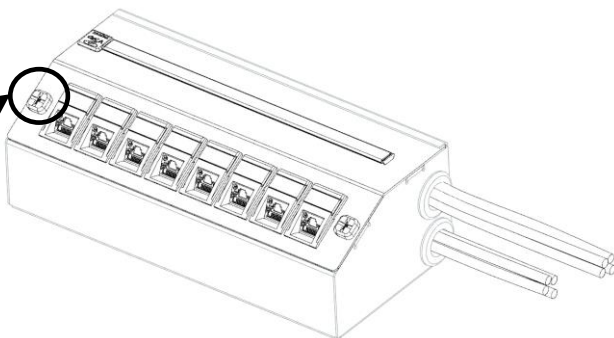

Fig.25

Installation Instructions for Generation-1 C6A DataGate Jack part no KSJ-00062-**.

1. ASSEMBLY INSTRUCTIONS

• TOOLS REQUIRED:

110 punch down tool, cable strippers, wire clippers, and screwdriver

1. Termination Tool

110 Termination tool set on low impact.

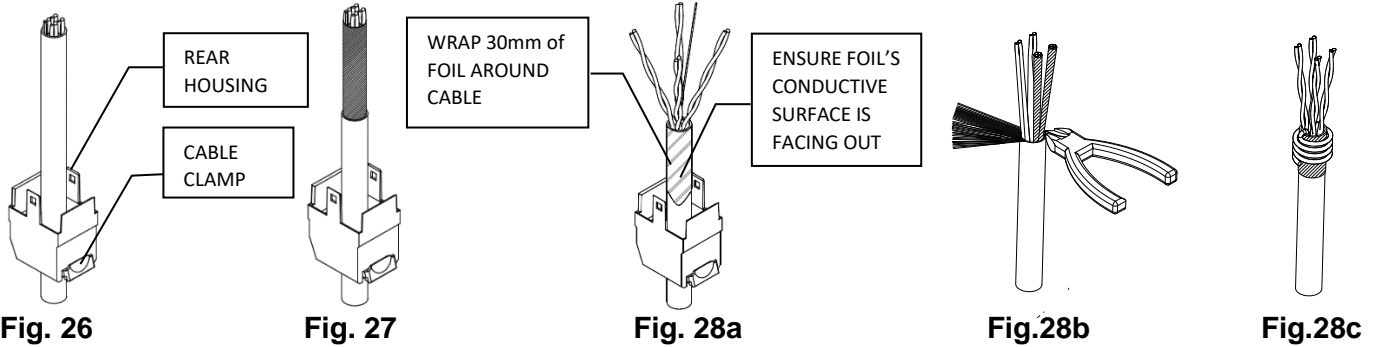

1.1 U/FTP cable preparation:

- 1.Ensure rear housing cable clamp is open (as showing in figures)
- 2.Slide rear housing on to cable (see Fig. 26)
- 3.Remove 75mm (3") of cable sheath with cable stripper (see Fig. 27)
- 4.Unwrap and remove 3 of the twisted pair's foils with wire clippers
- 5.Wrap approx. 30mm (1.2") of 4th foil down length of cable sheath (see Fig. 28a)
 - Ensure cable foil's conductive surface is facing out

1.2 F/UTP cable preparation:

- 1.Ensure rear housing cable clamp is open (as shown in figures)
- 2.Slide rear housing on to cable (see Fig. 26)
- 3.Remove 75mm (3") of cable sheath with cable stripper (see Fig. 27)
- 4.Unwrap overall foil from cable
- 5.Remove cable cellophane wrap and center section with wire clippers
- 6.Wrap approx. 30mm (1.2") of foil down length of cable sheath (see Fig. 28)
 - Ensure cable foil's conductive surface is facing out

1.3 S/FTP cable preparation:

- 1.Slide Rear Housing on to Cable (see Fig. 26)
- 2.Remove 75mm (3") of Cable sheath with Cable stripper (see Fig. 27)
- 3.Carefully split the braid along one side. (See Fig.28b)
- 4.Remove shield from three pairs. Use clippers to cut-off foil. Pull the foil shield back from the fourth pair over the jacket and wrap the bundle of braid around the shield. Ensure cable foil's conductive surface is facing out. (See Fig.28c)

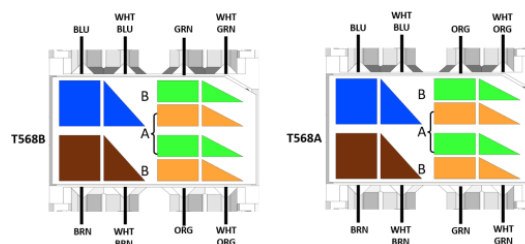

1.4 Cable termination to jack:

1. Wiring map (see Fig. 29)
2. Untwist cable pairs and punch down wires to corresponding- jack IDT contacts with 110 tool
3. Ensure wires are trimmed flush to IDT towers
4. Ensure cable sheath is maintained up to the jack

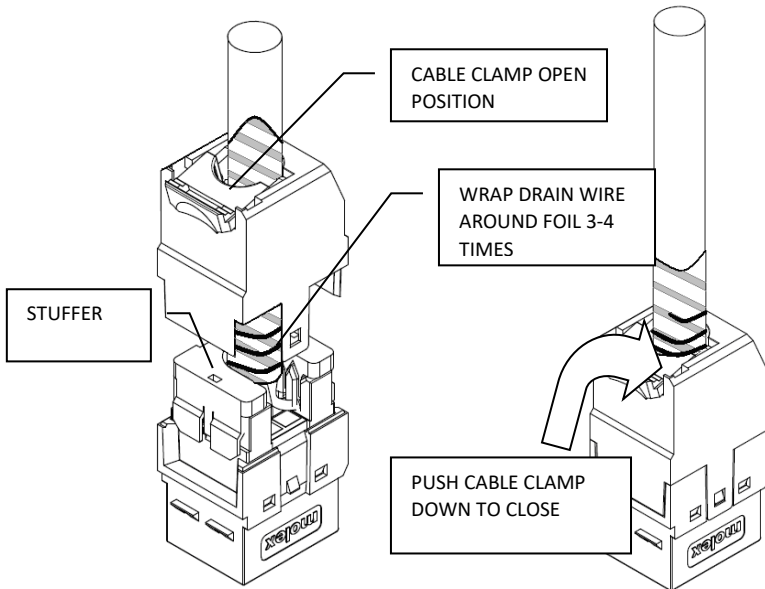

Fig. 30

Fig. 31

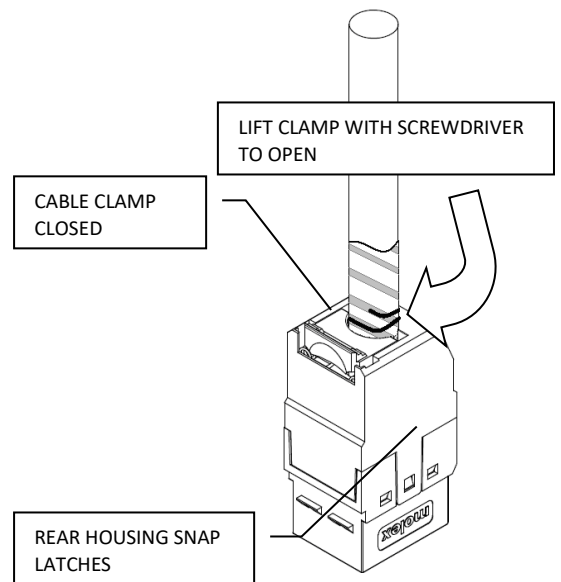

Fig. 32

To fit rear housing to jack:

1. Fit cable strain relief stuffer cap to IDT towers (see Fig. 30)
2. Wrap drain wire around cable foil 3 - 4 times (see Fig. 30)
3. Snap rear housing to jack (see Fig. 31)
4. Push clamp down to close clamp (see Fig. 31)
 - Ensure cable clamp clamps down on wrapped drain wire
 - Trim excess foil with clippers

To remove rear housing from jack:

1. Lift cable clamp with screwdriver (see Fig. 32)
2. Lift rear housing snap latches with screwdriver (see Fig. 32)
3. Pull rear housing apart from jack

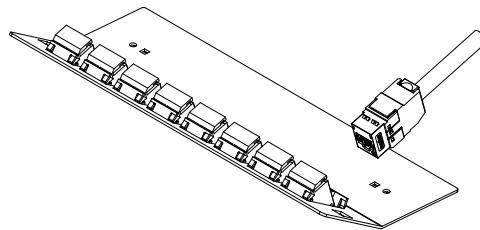

Fig. 33

To assemble jack to Consolidation Point Cover:

5. Orientate jack into module fascia as shown in Fig. 33
6. Slide in jack into module port opening at slight angle (see Fig. 34)
7. Insert the jack latches into base of module
8. Snap jack into module fascia by pushing down on top of jack (see Fig. 34)

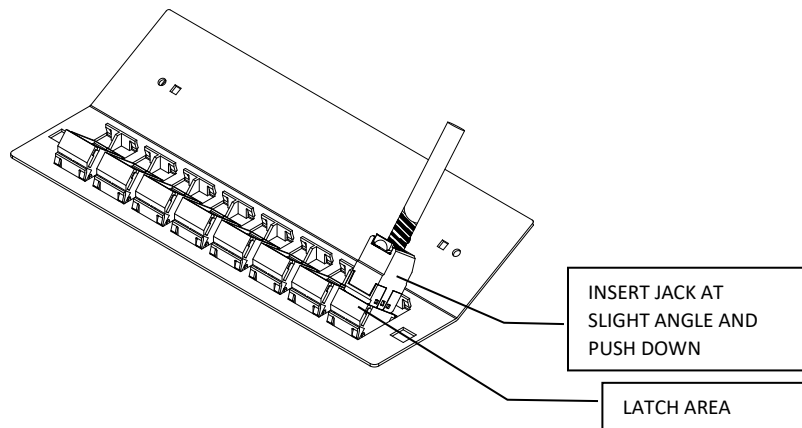

Fig. 34

ASSEMBLY AND CABLE DRESSING IN CONSOLIDATION POINT BOX

Dress Cables

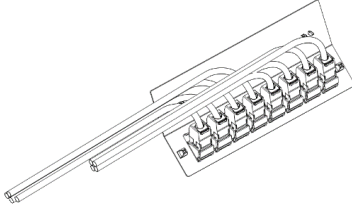

Fig-35

3. Arrange the Terminated cables as Fig-35
4. Pass 4 bundled cables through the grommet fitted cable exit hole. See Fig-38

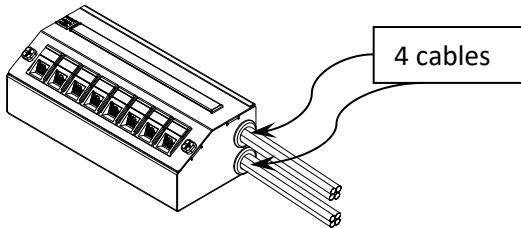

Fig-36

Fit Cover to Base

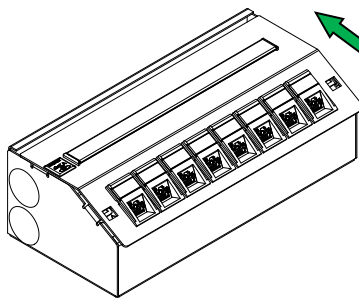

Fig-37

Slide the cover in to the opening of Box in the direction of arrow

Secure Cover by locating the snap-fit fastening, turn through 45° and push firmly they snap shut.

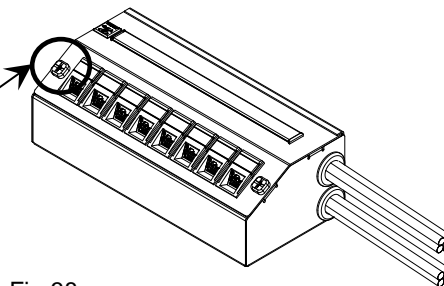

Fig-38